

# 9000 Series Application Guide

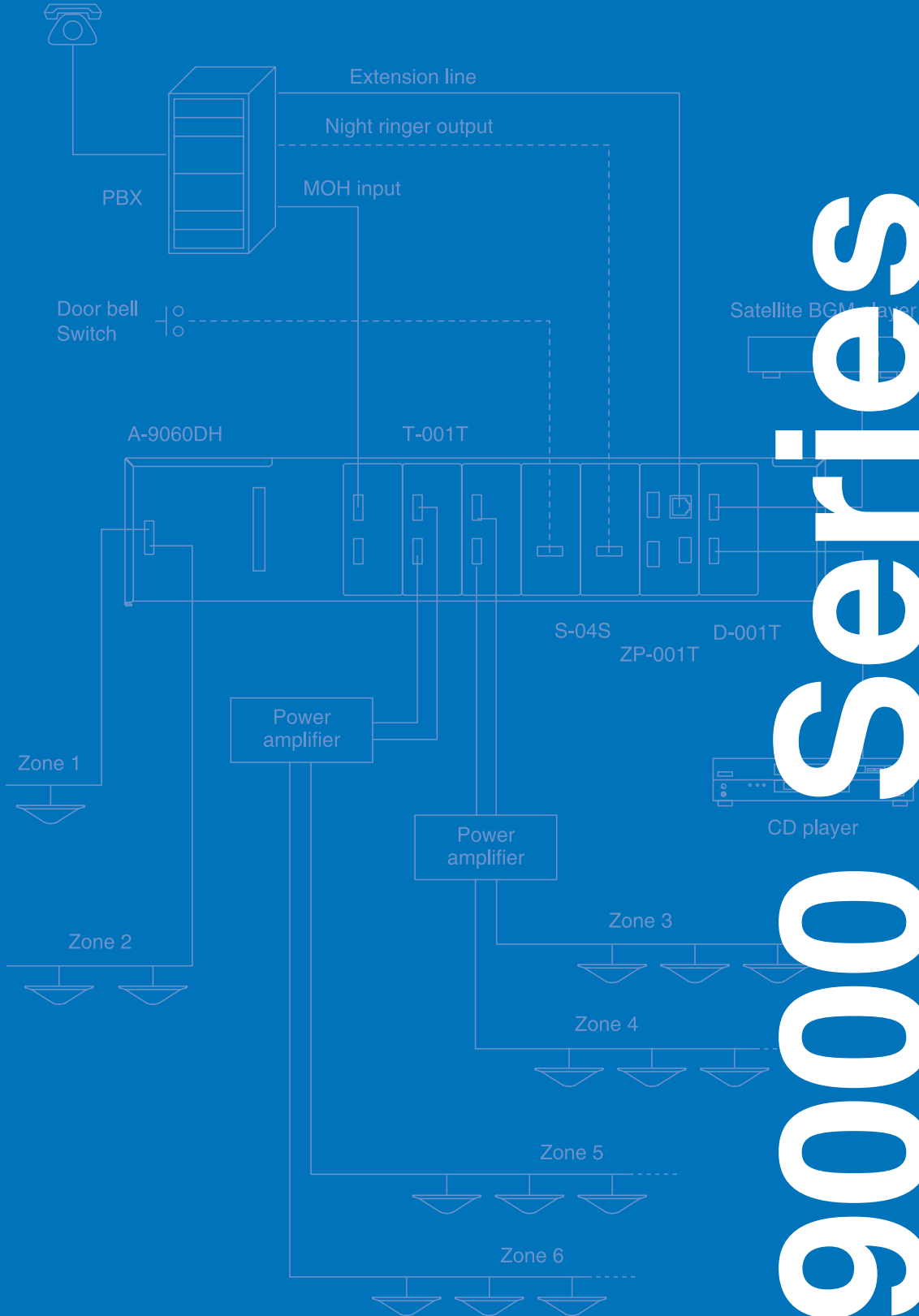

# 9000 Series

# Application Guide

# Table of Contents

**Introduction** ..... 3

**Chapter 1: Matrix Mode Applications**

- 1) Office/retail store: Telephone paging and Music-On-Hold ..... 4
- 2) Office/retail store/factory: Multi-zone paging ..... 5
- 3) Retail store: Multi-zone paging with night ringer and music-on-hold ..... 6
- 4) Restaurant/Bar: Multiple A/V sources, jukebox and zone paging ..... 7
- 5) Fitness club: Multiple music sources, zone paging and digital message repeater ..... 8

**Chapter 2: Mixer Mode Applications**

- 1) Hotel/banquet: Room combining ..... 9
- 2) Conference room: 4 microphone conference w./teleconferencing ..... 10
- 3) Church/auditorium: 8 microphones with auto-mixing ..... 11

## Welcome to the TOA 9000 Series Application Guide!

In this guide, you'll find several application examples to help you take advantage of the powerful flexibility of the 9000 series.

If you're designing a system to be used primarily for zone paging, you will find some examples in Chapter 1, using the 9000 series "Matrix mode." This mode provides a unique paging-oriented feature-set affording a high degree of flexibility for the routing of paging audio, as well as the ducking of background music, with variable mute depth and up to 8 priority levels.

If the system is for a more traditional mixing application, such as a board room, training room, auditorium, church, or hotel meeting room, or any application where zone paging is not needed, the 9000 series "Mixer mode" provides full matrix-mixing capability with easy-to-use front panel controls and a rich feature set including auto-mixing, cross-point gain controls, up to 32 complete "scene" presets, and one level of priority paging.

We hope you enjoy exploring the examples in this guide and that you'll find the 9000 Series mixer/amplifiers to be a helpful partner in your work.

# Chapter 1: Matrix Mode Applications

## 1) Office/retail store: Telephone paging and Music-On-Hold

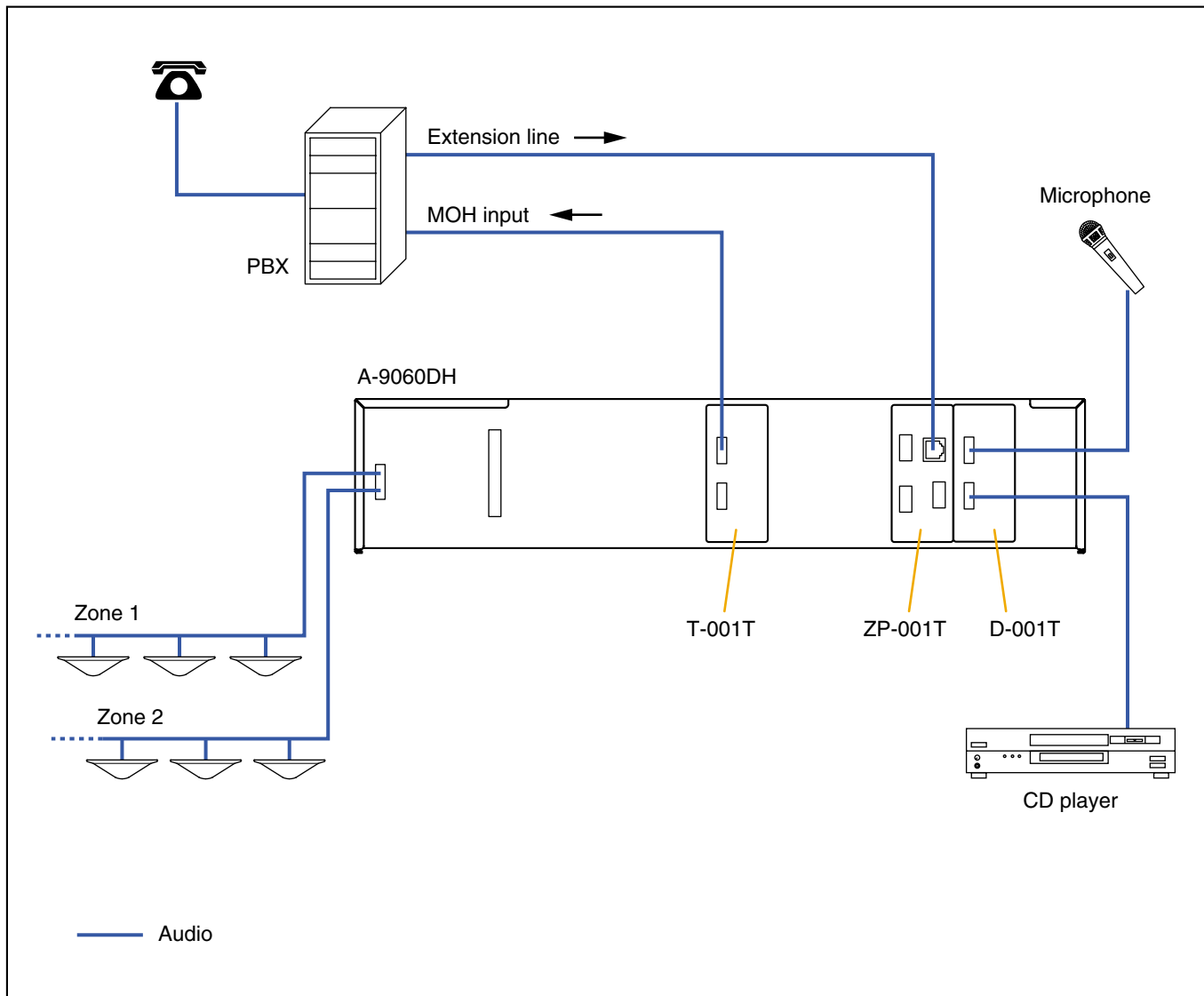

- Route the CD player music to Output 1 (Zone 1), Output 2 (Zone 2) and T-001T output. The T-001T output is connected to the MOH (Music-On-Hold) input of the PBX.
- Route the ZP-001T paging input to both Output 1 (Zone 1), Output 2 (Zone 2).
- A caller from one of the telephone extension lines of the PBX can page through the amplifier by dialing the extension number connected to the ZP-001T and the zone number.
- MOH music will never stop even when Zone 1 or Zone 2 is paged.

## 2) Office/retail store/factory: Multi-zone paging

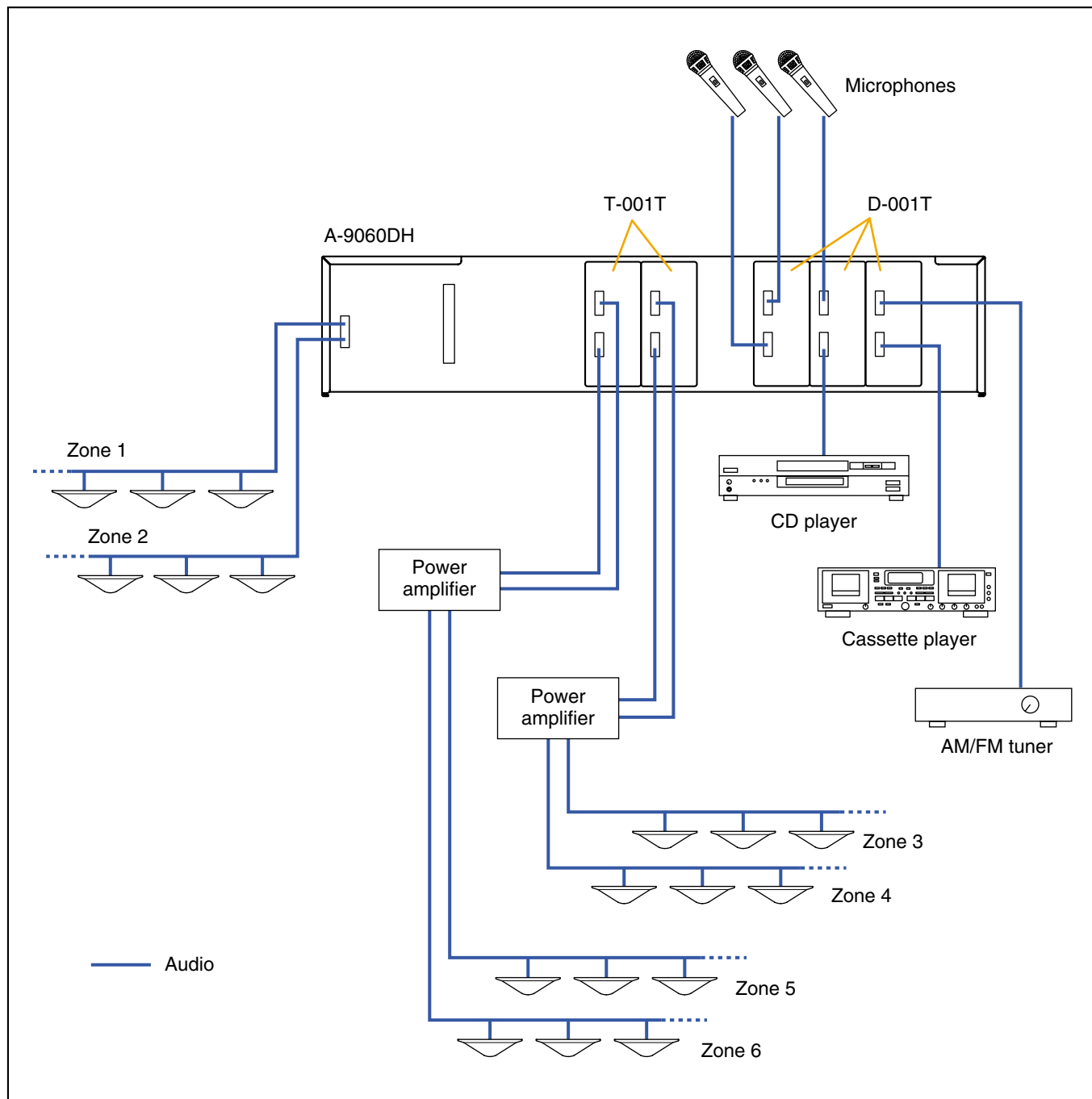

- Route each input to desired outputs (zones). Assign a higher priority for each microphone input over BGM sources.
- Also activate "VOX" function for each microphone input to enable "paging over BGM."

### 3) Retail store: Multi-zone paging with night ringer and music-on-hold

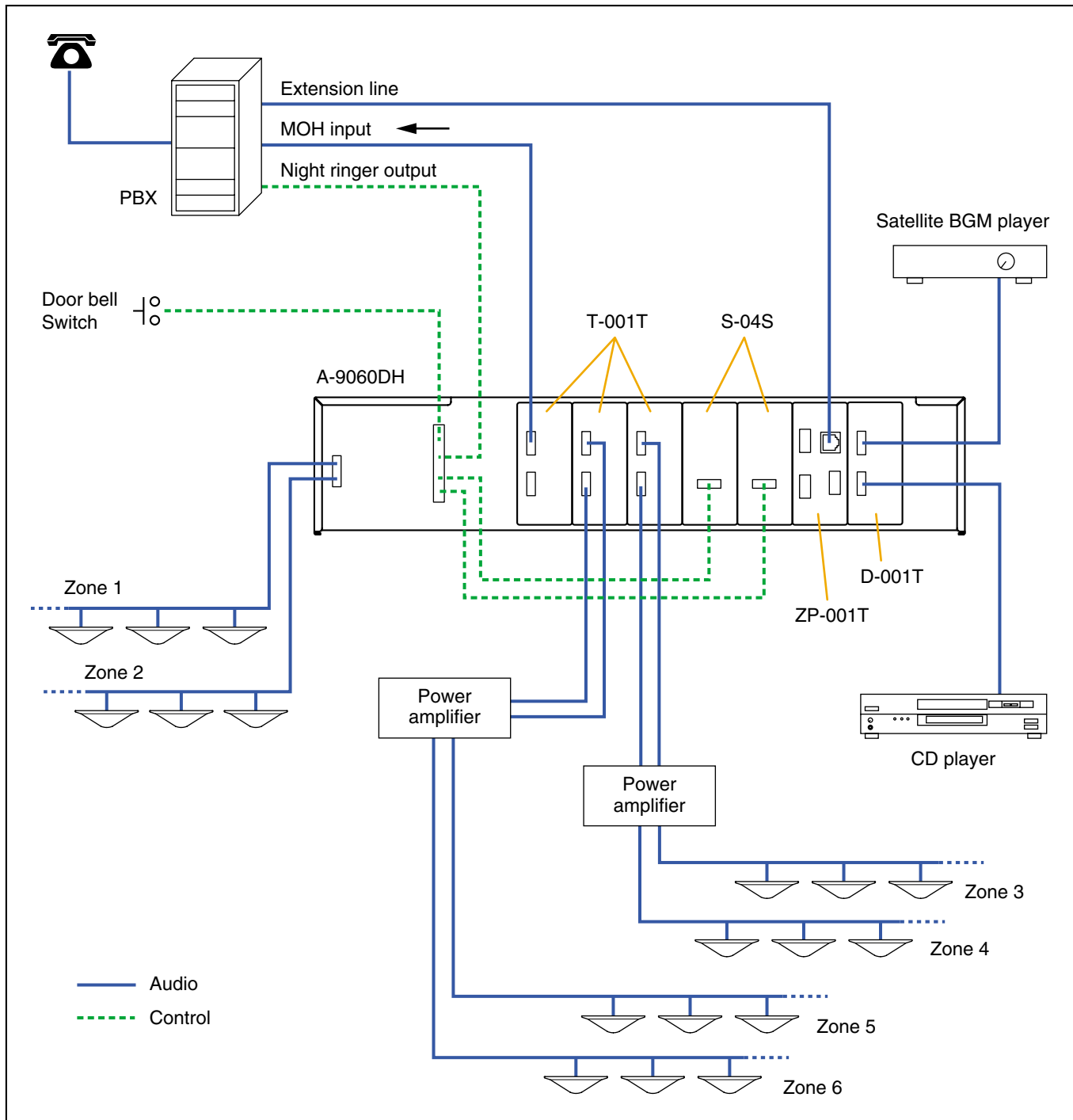

- Combination of multi-zone paging and telephone paging system, adding night ringer function.
- BGM from the satellite BGM player or the CD player is distributed to each zone.
- BGM from the satellite BGM player or the CD player is also distributed to the MOH input of the PBX.
- Program an "event" that the S-04S signal will be distributed to a designated zone to hear the door bell ring. Assign the door-bell switch control input to activate the "event" as well as control output to drive the S-04S contact closure input.
- Program another "event" that the other S-04S signal will be distributed to a designated zone to hear the night ringer. Assign control input connected to "night ringer output" from the PBX system to activate the "event" as well as other control output to drive the S-04S contact closure input.

#### 4) Restaurant/Bar: Multiple A/V sources, jukebox and zone paging

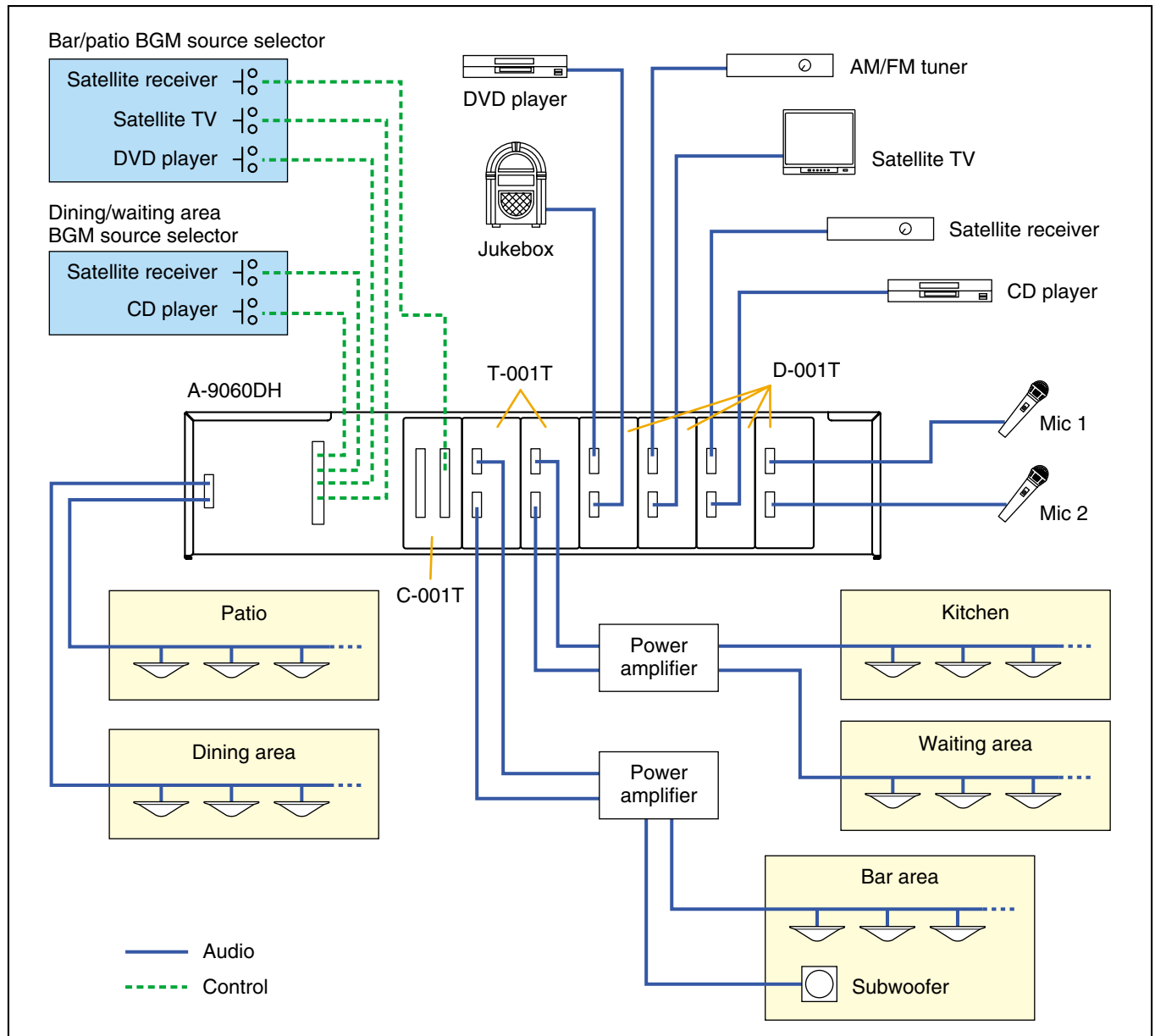

- Multiple A/V sources distributed to dining area, bar area, waiting area, patio and kitchen.
- Subwoofer will be installed in the bar area to have better low-boosted sound.
- Routing patterns are as follows.
  - Mic 1: waiting area, bar area and patio
  - Mic 2: kitchen
  - CD player and satellite receiver: dining area, bar area, waiting area and patio
  - DVD player and satellite TV: bar area and patio
  - Jukebox: bar area
  - AM/FM tuner: kitchen
- Two input selectors will work as follows.
  - Switches for Satellite Receiver and CD Player will be used to select the background music source for the dining and waiting areas.
  - Switches for Satellite Receiver, Satellite TV, and DVD Player will be used to select the background music source for the bar and patio. In these areas, the Jukebox will automatically override the background music.
- Set "speaker EQ" for each output to Bar area. For the subwoofer, assign a subwoofer preset EQ pattern, for example, "FB-120".

### 5) Fitness club: Multiple music sources, zone paging and digital message repeater

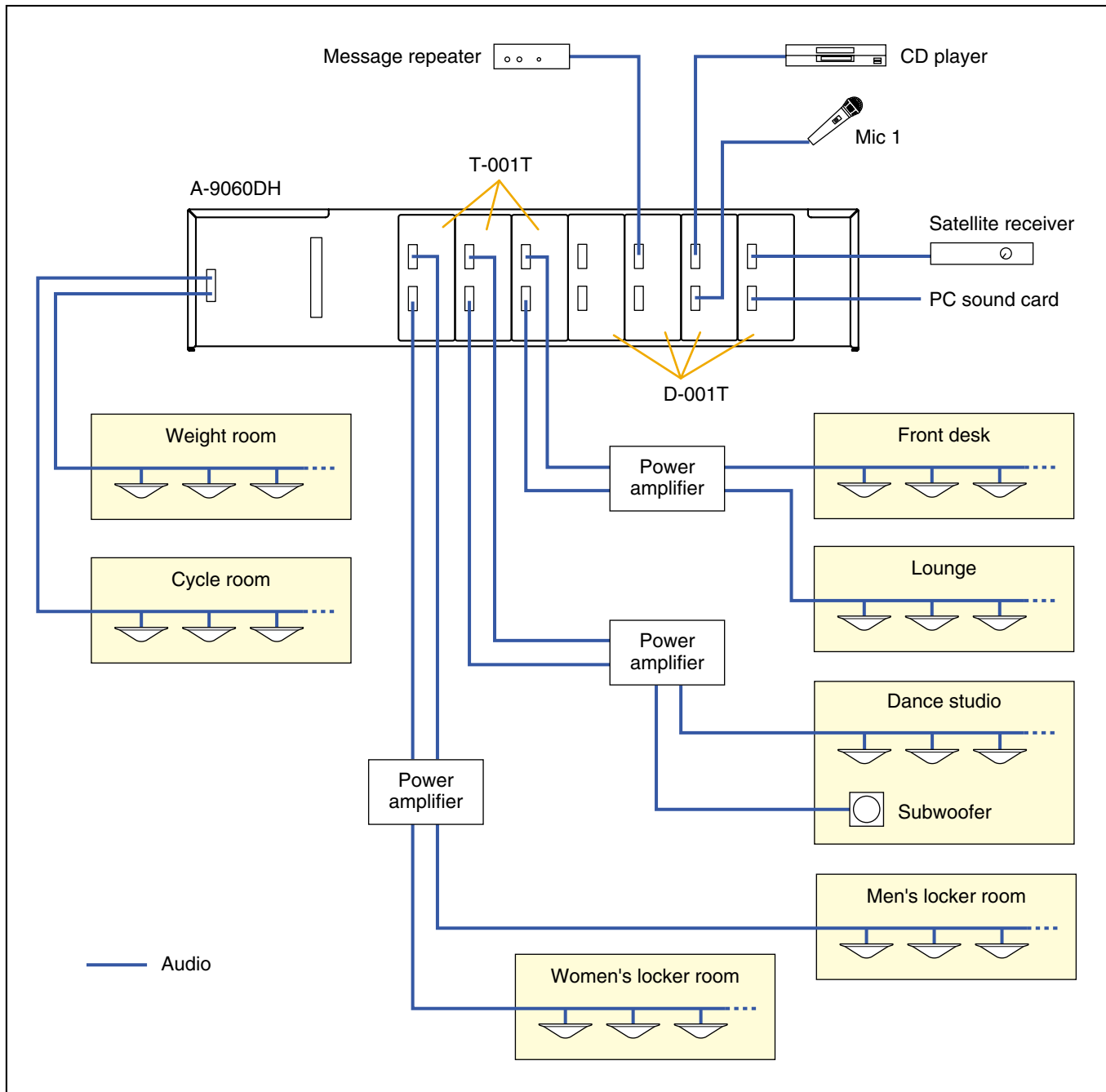

- Multiple music sources distributed to front desk, lounge, dance studio, weight room, cycle room and men's/women's locker rooms.
- Routing patterns are as follows.
  - Satellite receiver/PC audio: front desk, lounge and men's/women's locker rooms
  - CD player: dance studio
  - Mic 1: all areas
  - Message repeater: for pre-programmed announcement to all areas except dance studio
- Program Mic1 and message repeater to take priority over the music.
- Set "speaker EQ" for each output to dance studio. For the subwoofer, assign a subwoofer preset EQ pattern, for example, "FB-120".
- Set limiter function for each output.

## Chapter 2: Mixer Mode Applications

### 1) Hotel/banquet: Room combining

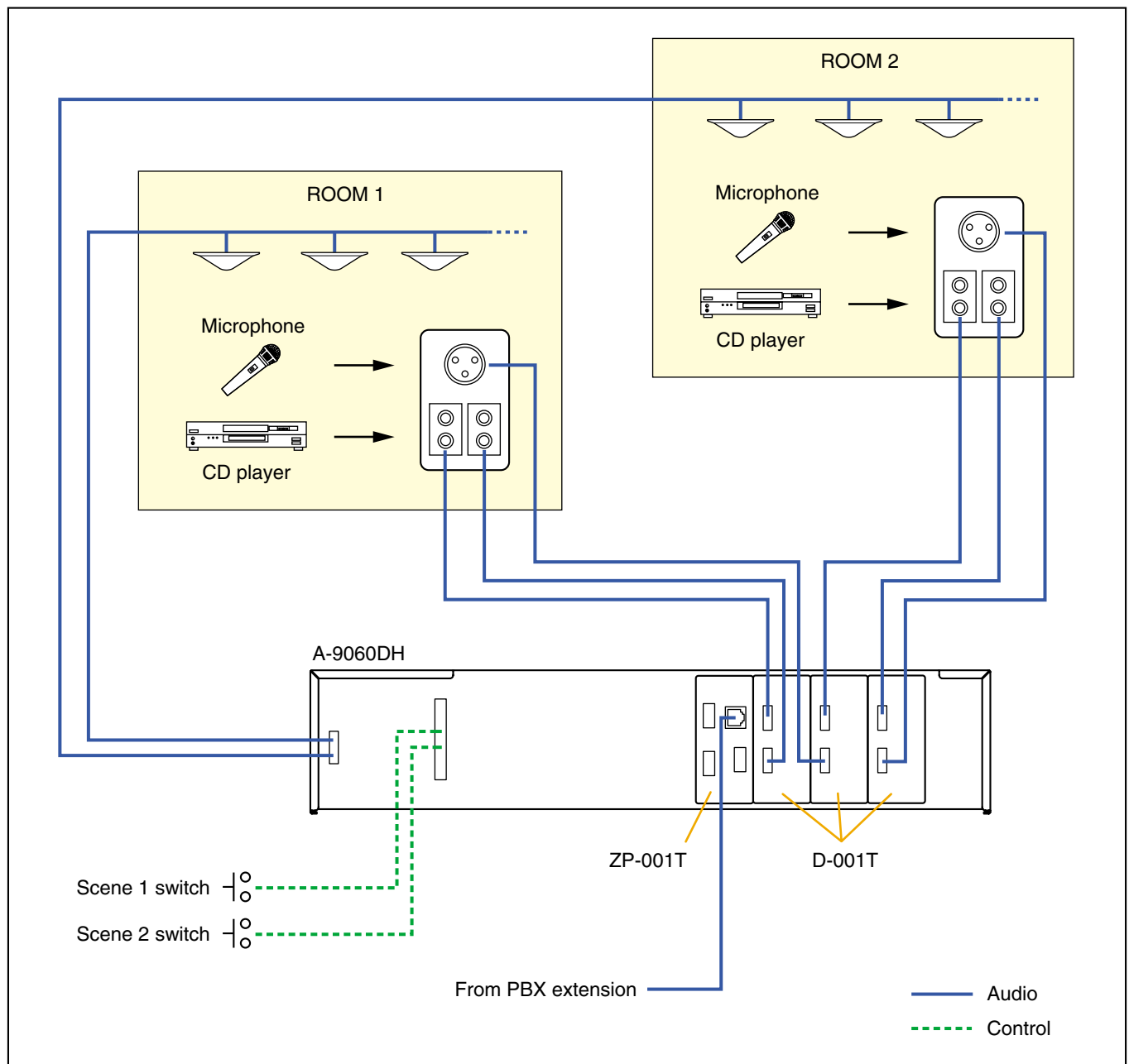

- Create two different preset "scenes."
- Scene 1 – Rooms separate: Route room 1 inputs to room 1 speakers, and route room 2 inputs to room 2 speakers.
- Scene 2 – Rooms combined: Route all inputs to both outputs.
- Connect two momentary switches to the control input terminals, and program the first control input to activate scene 1 and the second control input to activate scene 2. The control outputs can be used to control LEDs indicating the system status. Alternatively, a toggle switch may be used.

## 2) Conference room: 4 microphone conference w./teleconferencing

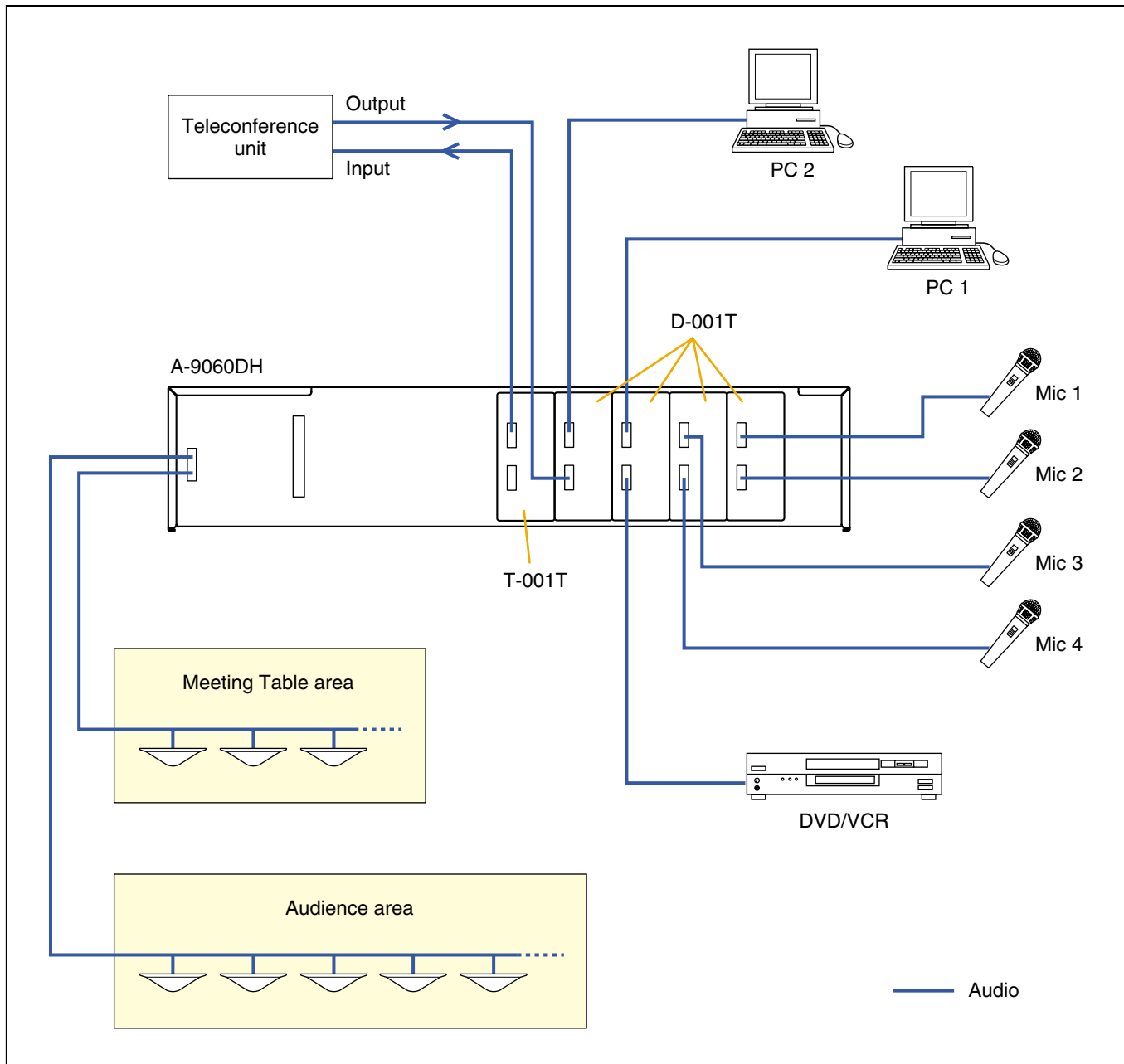

- Microphone audio will be routed to meeting table area as well as audience area and teleconference unit. Microphone audio level in meeting table area will be 6 dB quieter.
- DVD/VCR, PC 1 and PC 2 audio will be routed to meeting table area, audience area and teleconference unit.
- Teleconference unit output will be routed only to meeting table area and audience area.
- The microphones will be controlled under NOM (number of open microphones) auto-mixing function.
- The input channel connected to teleconference unit output will be set for compressor #4.

### 3) Church/auditorium: 8 microphones with auto-mixing

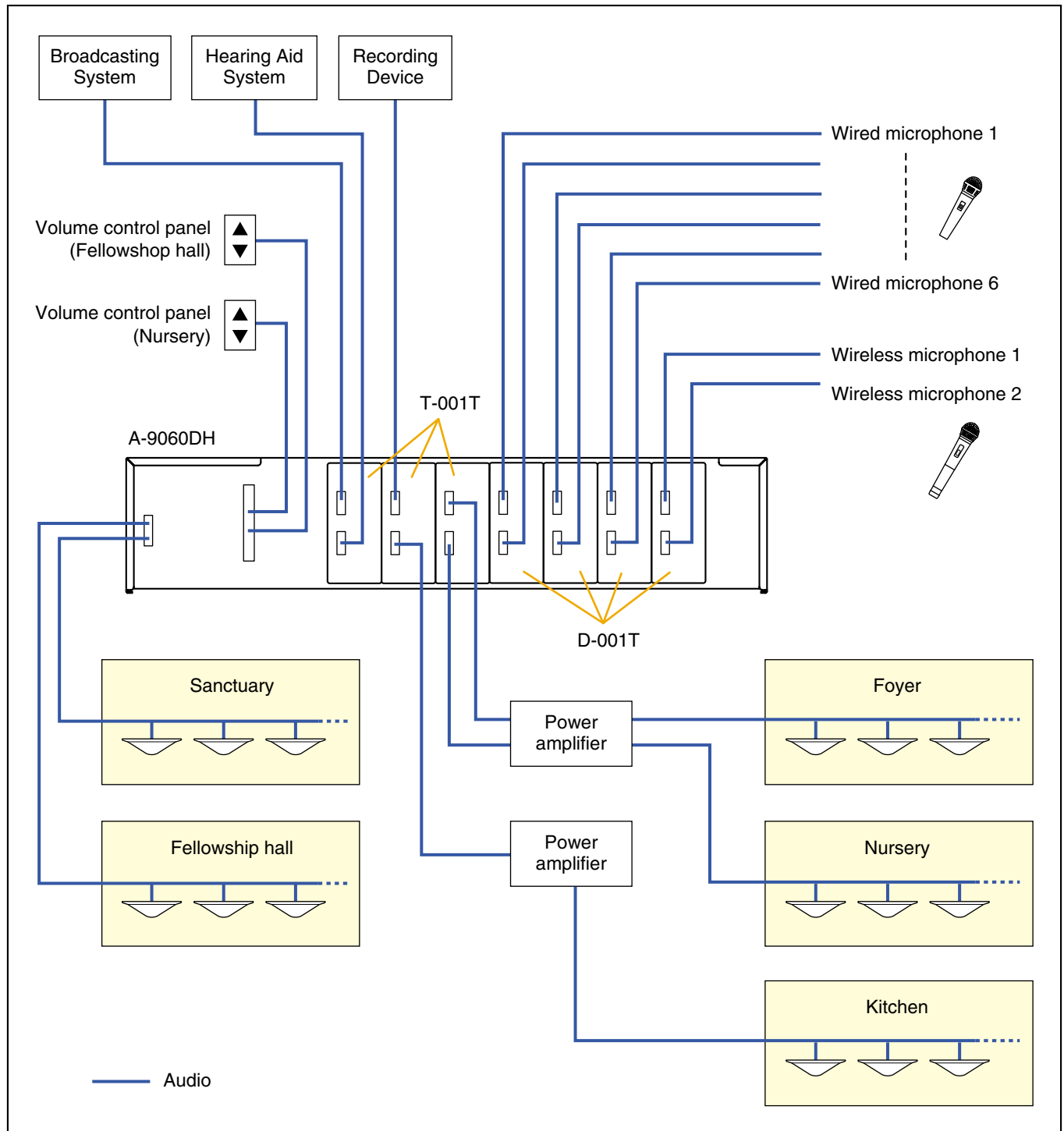

- All of the microphones will be routed to all areas and outputs including recording device, hearing aid system and broadcasting system.
- Gate and NOM (number of open microphones) auto-mixing function is applied to all of the microphone inputs. Each microphone input can be equalized using 10 band parametric EQ per input.
- Wall mount panel with volume up/volume down buttons controls volume in nursery and fellowship hall.
- Each speaker output can be equalized using 10 band parametric EQ per output.
- Use compressor setting #1 (speech) or #2 (vocalist) for each microphone input.

# 9000 Series Application Guide

