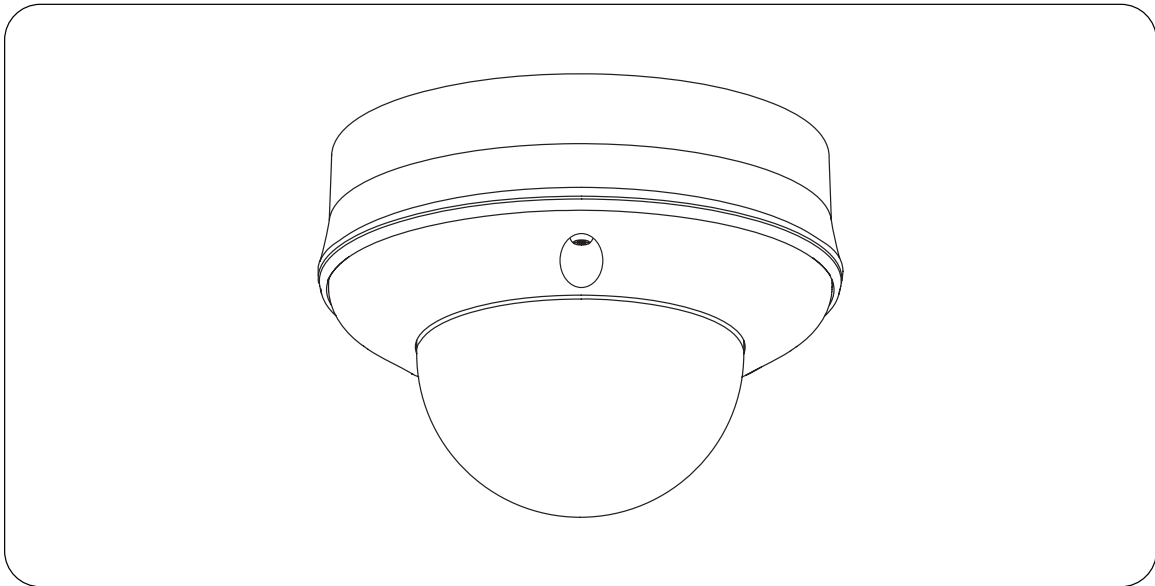

**VANDAL RESISTANT
DAY/NIGHT CAMERA**
**C-CV854D-3 CU
C-CV854D-9 CU
C-CV854D-3 CE**

TABLE OF CONTENTS

1. SAFETY PRECAUTIONS	2	6. CONNECTION	11
2. GENERAL DESCRIPTION	4	7. ADJUSTMENT	12
3. HANDLING PRECAUTIONS	4	8. ABOUT THE MODE SETTING SWITCH	
4. NOMENCLATURE	5	8.1. Focus adjustment switch	13
5. INSTALLATION		8.2. Backlight compensation switch	13
5.1. Detaching a Dome Cover	6	8.3. Flickerless switch	13
5.2. Installing a Camera	6	8.4. ATW/AWB selection switch	14
5.2.1. Unexposed wiring	6	8.5. Mode selection switch	14
5.2.2. Open wiring		9. TROUBLESHOOTING	14
from the camera's side	8	10. SPECIFICATIONS	15
5.3. Attaching a Dome Cover	10	Accessories	16

Thank you for purchasing TOA's Vandal Resistant Day/Night Camera. Please carefully follow the instructions in this manual in order to ensure long, trouble-free use of your color camera.

1. SAFETY PRECAUTIONS

- Before installation or use, be sure to carefully read all the instructions in this section for correct and safe operation.
- Make sure to observe the instructions in this manual as the conventions of safety symbols and messages regarded as very important precautions are included.
- We also recommend you keep this instruction manual handy for future reference.

Safety Symbol and Message Conventions

Safety symbols and messages described below are used in this manual to prevent bodily injury and property damage which could result from mishandling. Before operating your product, read this manual first and understand the safety symbols and messages so you are thoroughly aware of the potential safety hazards.



WARNING

Do not leave the unit upside-down where it could be exposed to the rain or elements. Water in the unit may cause shorts that could result in fire or electrical shock.



WARNING

Indicates a potentially hazardous situation which, if mishandled, could result in death or serious personal injury.

- Use the unit only with the voltage specified on the unit. Using a voltage higher than that which is specified may result in fire or electric shock.
- Use screws that are appropriate for the ceiling's or wall's structure and composition. Failure to do so may cause the unit to fall, resulting in material damage and possible personal injury.
- Ensure that all screws and fixing mechanism are securely tightened. If they are not tightened or firmly secured after installation, the unit could fall down, possibly resulting in personal injury.
- Install the unit only in a location that can structurally support the weight of the unit and the mounting bracket. Doing otherwise may result in the unit falling down and causing personal injury and/or property damage.
- Avoid installing the unit in locations exposed to sea breeze or corrosive gas. The unit or its mounts may be subject to corrosion, that might cause it to fall or result in other accidents.
- To prevent a fire or electric shock, never open nor remove the unit case as there are high voltage components inside the unit. Refer all servicing to qualified service personnel.
- If any of the following irregularities occurs, immediately switch off the power, and inform the shop from where the unit was purchased. Further using the unit may result in fire or electric shock.
 - If you detect smoke or a strange smell coming from the unit.
 - If water or any metallic object gets into the unit
 - If the unit falls, or the unit case breaks
 - If the power supply cord is damaged (exposure of the core, disconnection, etc.)
 - If it is malfunctioning (no image appears.)
- Do not mount the unit in locations exposed to constant vibration. The mounting screws and/or bolts may be loosened by excessive vibration, potentially causing the unit to fall, which could result in personal injury.
- To prevent lightning strikes, install the unit at least five meters away from a lightning rod, and yet within the protective range (angle of 45°) of the lightning conductor. Lightning strikes may cause a fire, electric shock or personal injury.
- Do not insert nor drop metallic objects or flammable materials in the ventilation slots of the unit's cover, as this may result in fire or electric shock.



CAUTION

Indicates a potentially hazardous situation which, if mishandled, could result in moderate or minor personal injury, and/or property damage.

- Leave the installation of the unit to your TOA dealer because the installation requires expert experience and skills. The unit may fall off if incorrectly installed, resulting in possible personal injury.
- Do not stand or sit on, nor hang down from the unit as this may cause it to fall down or drop, resulting in personal injury and/or property damage.
- Have the unit checked periodically by the shop from where it was purchased. Failure to do so may result in corrosion or damage to the unit or its mounting bracket that could cause the unit to fall, possibly causing personal injury.
- Switch off the power for safety purposes when cleaning or leaving the unit unused for 10 days or more. Doing otherwise may cause a fire or electric shock.

CU version complies with Part 15 of the FCC Rules.

Note

This equipment has been tested and found to comply with the limits for a Class B digital device, pursuant to Part 15 of the FCC Rules. These limits are designed to provide reasonable protection against harmful interference in a residential installation. This equipment generates, uses and can radiate radio frequency energy and, if not installed and used in accordance with the instructions, may cause harmful interference to radio communications. However, there is no guarantee that interference will not occur in a particular installation. If this equipment does cause harmful interference to radio or television reception, which can be determined by turning the equipment off and on, the user is encouraged to try to correct the interference by one or more of the following measures:

- Reorient or relocate the receiving antenna.
- Increase the separation between the equipment and receiver.
- Connect the equipment into an outlet on a circuit different from that to which the receiver is connected.
- Consult the dealer or an experienced radio/ TV technician for help.

Modifications

Any modifications made to this device that are not approved by TOA Corporation may void the authority granted to the user by the FCC to operate this equipment.

This device complies with Part 15 of the FCC Rules. Operation is subject to the following two conditions: (1) this device may not cause harmful interference, and (2) this device must accept any interference received, including interference that may cause undesired operation.

This Class B digital apparatus complies with Canadian ICES-003.

Cet appareil numérique de la classe B est conforme à la norme NMB-003 du Canada.

2. GENERAL DESCRIPTION

The TOA C-CV854D-3 and C-CV854D-9 are Vandal Resistant Day/Night Camera equipped with a Day/Night function. It functions as a color camera in the daytime and as a high-sensitivity monochrome camera in darkness, making it ideal for installation in locations that require around-the-clock monitoring. Noise reduction function enables clear image to be viewed in lower noise under poor lighting conditions. Its dust-proof and waterproof (IP66) construction permits it to be mounted to an outdoor wall or ceiling without using a special device to protect the camera against dust or rain. Since the camera unit is constructed of die-cast aluminum alloy and its dome cover is made of polycarbonate, the C-CV854D-3 and C-CV854D-9 ensure high resistance to strong impacts. It features a 3-axis (horizontal, vertical and rotation) adjustment mechanism and a vari-focal lens which facilitate adjustment of camera orientation and angle of view at the time of installation. The use of an optional built-in heater unit allows the C-CV854D-3 and C-CV854D-9 to be used at ambient temperatures as low as -30°C (-22°F).

3. HANDLING PRECAUTIONS

- Do not direct the camera lens to the sun or strong lighting or light reflection. Exposure to direct sunlight could cause the CCD's color filter to deteriorate, leading to image discoloration.
- Do not give the camera a great shock or vibration, as this will damage the camera.
- It is recommended that the camera be always used in locations where the ambient temperature ranges from -10°C to +50°C (14°F to 122°F) and humidity levels of less than 90% to ensure that no condensation is formed.
- To clean, wipe with a dry soft cloth. Never use benzene, thinner or chemically processed towel as the camera's plastic or other parts may be deformed or discolored.
- When dust has settled on the unit's lens, lightly clean using a commercial camera blower or cleaning paper.
- Installing the camera cables in close proximity to fluorescent lamps or other electrical appliances can downgrade the picture quality. In such cases, change the wiring.
- If there is a strong electric or magnetic field near the camera, such as television transmission antennas, motors or transformers, this may distort or roll the monitor picture. In such cases, run the entire wiring route through metal conduit tubing.
- Do not install the unit in locations where solvents or chemicals are used as the unit's dome cover may be deformed or discolored.
- Use the external power supply unit of the following rating when the camera is operated on 12 V DC.
12 V DC, over 1.0 A
- Since the Day/Night Camera features sealed construction, condensation can build up inside the camera, causing the inside of the dome cover to fog. Ensure that the camera is installed under low humidity conditions.
- Avoid installing the Day/Night Camera in locations exposed to cold air or close to an air-conditioner vent, as the dome cover may become fogged.

4. NOMENCLATURE

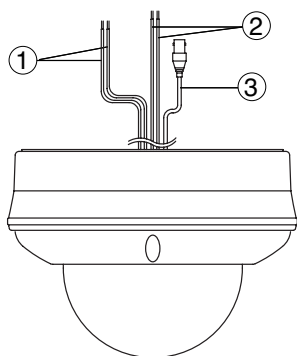

[Side view with a dome cover attached]

[Side view with an inner cover detached]

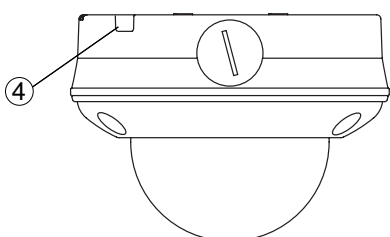

[Bottom view with a dome cover attached]

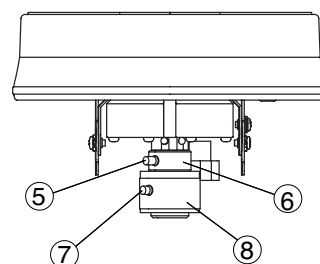

[Bottom view with an inner cover detached]

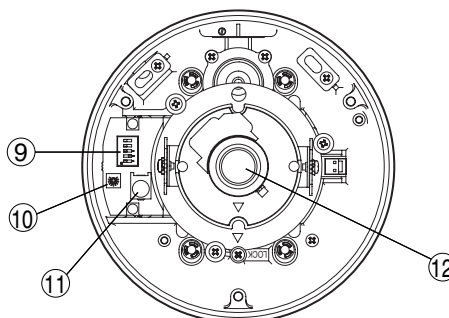
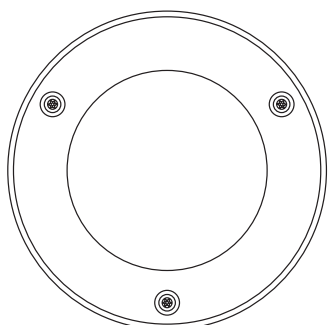

- (1) Camera power input cable (Red, Black)
(24 V AC or 12 V DC)
- (2) Heater power input cable (White, White)
(24 V AC)
- (3) Video output terminal (cable with BNC)
- (4) Safety wire fixing hole (M4)
- (5) Zoom ring fixing screw
- (6) Zoom ring

- (7) Focus ring fixing screw
- (8) Focus ring
- (9) Mode setting switch
- (10) Iris control
- (11) Monitor output terminal (RCA pin jack)
- (12) Vari-focal lens

5. INSTALLATION

Notes

- Do not remove the protective sheet attached to the dome cover until installation work is completed. Damage to the dome cover could result if the protective sheet is removed during installation.
- A safety wire for connecting between the unit and ceiling is not supplied. Hook a safety wire for the unit itself to the safety wire-fixing hole (M4, useful thread depth = 6 mm (0.24 inch)) as needed.
- Wrap self-adhesive insulation tape around coaxial cable connections and the power supply lead.

5.1. Detaching a Dome Cover

1. Detach the dome cover from the case.
Remove three screws fixing the dome cover with a supplied L-type wrench.

Notes

- The dome cover is connected to the case by a safety wire.
 - You may find that an O-ring placed into the groove of the dome cover is about to come off when detaching the dome cover. In such cases, replace the O-ring into the groove securely.
 - After detaching the dome cover from the case, do not lift the camera unit by the inner cover. If lifted, the inner cover can be unhooked, and the camera could fall off, possibly resulting in personal injuries or causing damage to the camera.
2. Detach the inner cover while pushing two of the sections indicated by arrows.

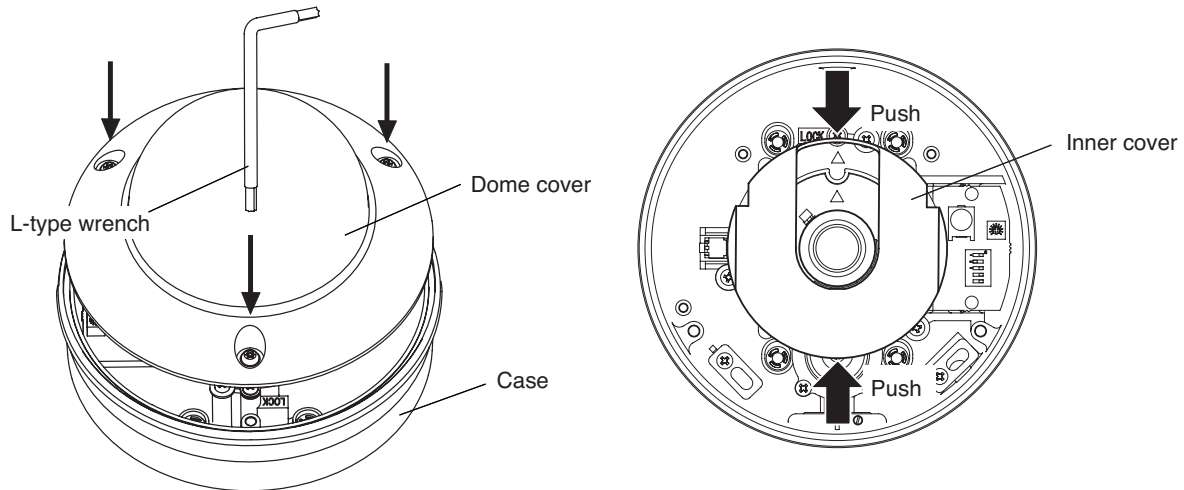

5.2. Installing a Camera

5.2.1. Unexposed wiring

1. Make a cable entry hole as shown below in the ceiling or wall.

Note

When mounting the camera to a wall, make sure the cable entry hole is positioned below the camera center.

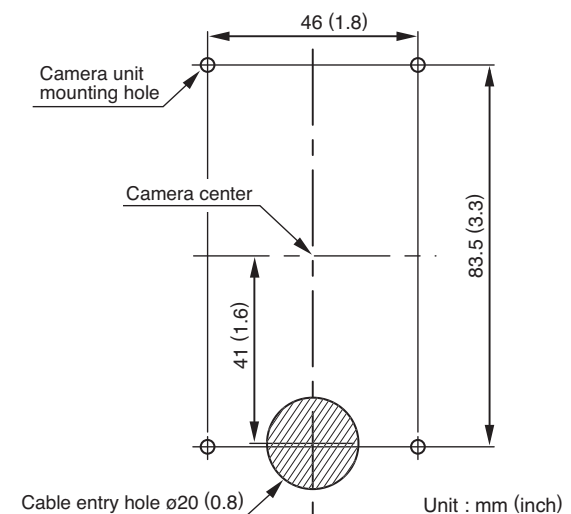

2. Connect a coaxial cable to the Video output terminal, and connect the Camera power input cable and power wire from the power-supply unit.
3. Fix the camera unit to the ceiling or wall using the four mounting screws.
Attach the supplied base gasket to the camera unit, then install the camera unit to the ceiling or wall. Since no mounting screws are supplied with the camera, prepare them separately depending on the situation.
(Use screws that are over 4 mm (0.16 inch) in nominal diameter and longer than 25 mm (1 inch).)

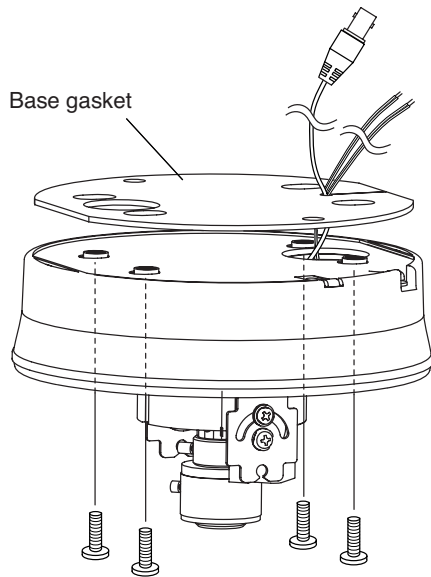

Note

The cable trench and four camera mounting holes must be protected with silicone sealant material to prevent rainwater from leaking into the enclosure. Do not waterproof other holes.

[Cable trench]

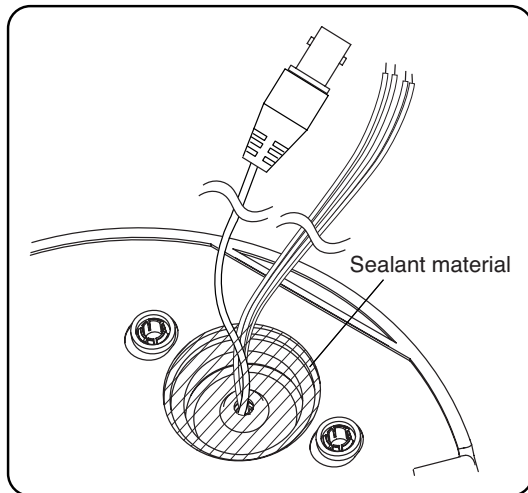

[Camera mounting holes]

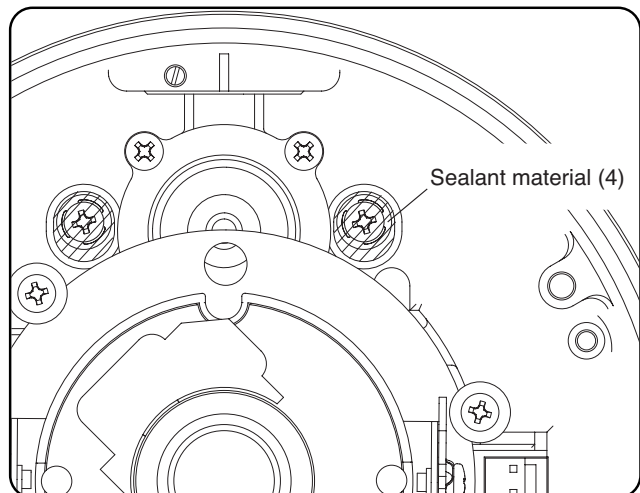

5.2.2. Open wiring from the camera's side

Note

The pipe receptacle thread on the camera's side is compatible with 3/4-inch threaded conduit.

1. Loosen the fixing screw with a standard driver, then detach the camera side-attached pipe receptacle thread cover.

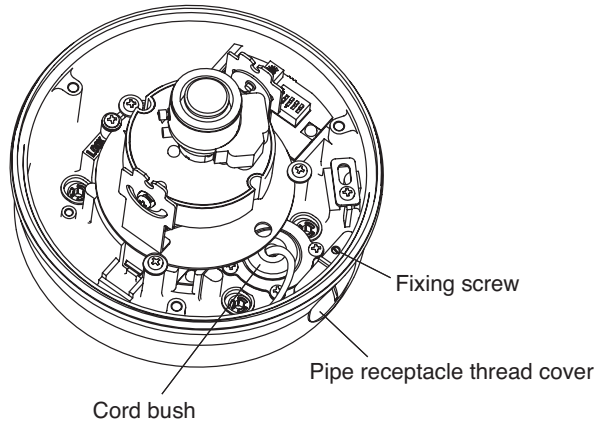

2. Push in the cord bush attached to the camera unit from the back to pull out from the case. Run the cable and lead it out from the camera pipe receptacle thread hole.

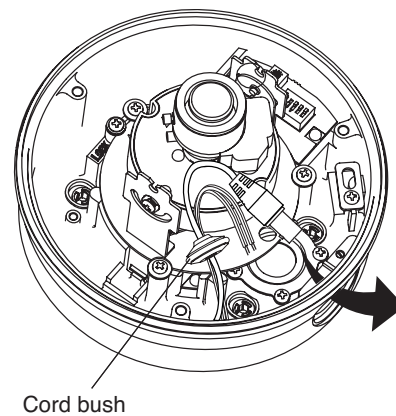
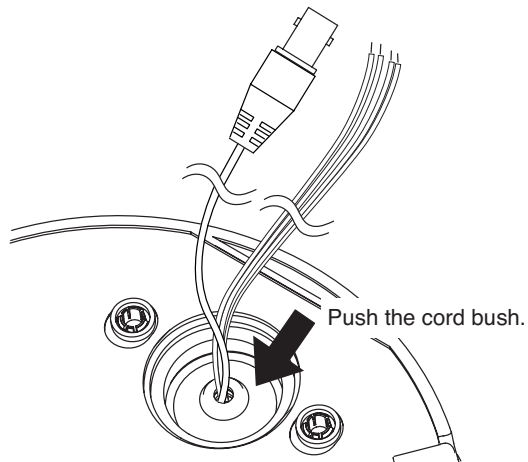

3. Attach the removed pipe receptacle thread cover to the threaded section at the upper surface of the camera unit.
4. Wrap two or more layers of sealing tape around the pipe's threaded section, then screw the pipe into the camera's threaded receptacle.
Sealing tape must be wrapped around the pipe's threaded part. The pipe to be used must be approximately 100 mm (3.9 inch) in length.

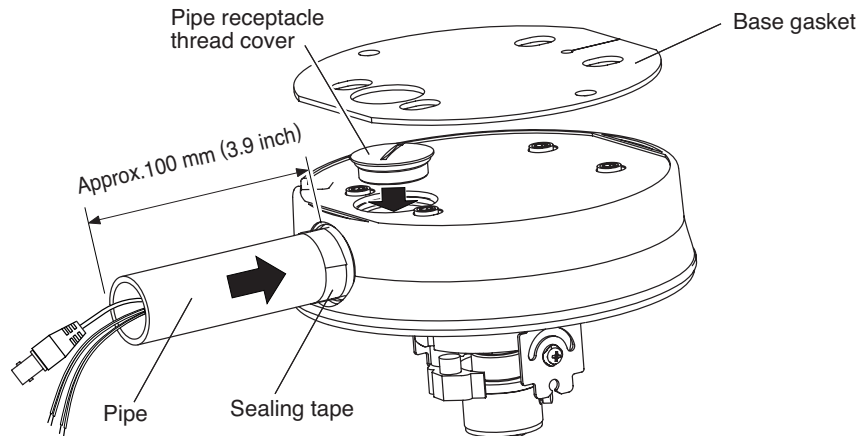

5. Connect a coaxial cable to the Video output terminal, and connect the Camera power input cable and power wire from the power-supply unit.
6. Fix the camera unit to the ceiling or wall using the four mounting screws.
Attach the supplied base gasket to the camera unit, then install the camera to the ceiling or wall. Since no mounting screws are supplied with the camera, prepare them separately depending on the situation. (Use screws that are over 4 mm (0.16 inch) in nominal diameter and longer than 25 mm (1 inch).) Further, when using a coupling, join the pipe mounted to the camera to the pipe coming out of the device to be connected. When installing the camera unit to a wall, install the camera unit so that its pipe faces down.

Note: The 4 camera mounting holes must be protected with silicone sealant material to protect rainwater from leaking into the enclosure.

5.3. Attaching a Dome Cover

1. After camera's angle of view and focus adjustment completion, attach the inner cover.

1-1. Put the inner cover in the way that the lens comes to the opening slit of the inner cover. Fit one emboss of the inner cover at a time in the cover-mounting hole while pushing two of the sections indicated by arrows.

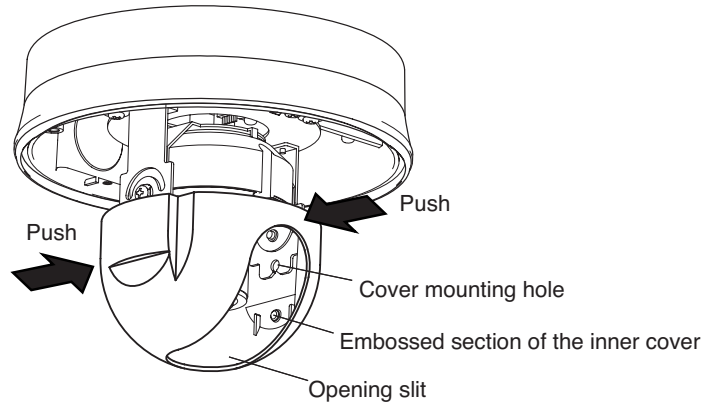

1-2. After attaching the inner cover, check to be sure that inner cover is securely fitted to the camera unit by pulling down the sections indicated by arrows tightly.

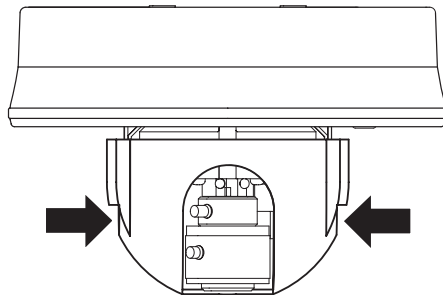

2. Attach the dome cover.

Check to be sure that the safety wire is not pinched between the dome cover and case. Dustproof and water-resistance features could be adversely affected.

6. CONNECTION

Note: If the Video output is not terminated at 75Ω , camera images are not properly displayed. Make sure that the output has been terminated at 75Ω at the connected monitor or switcher.

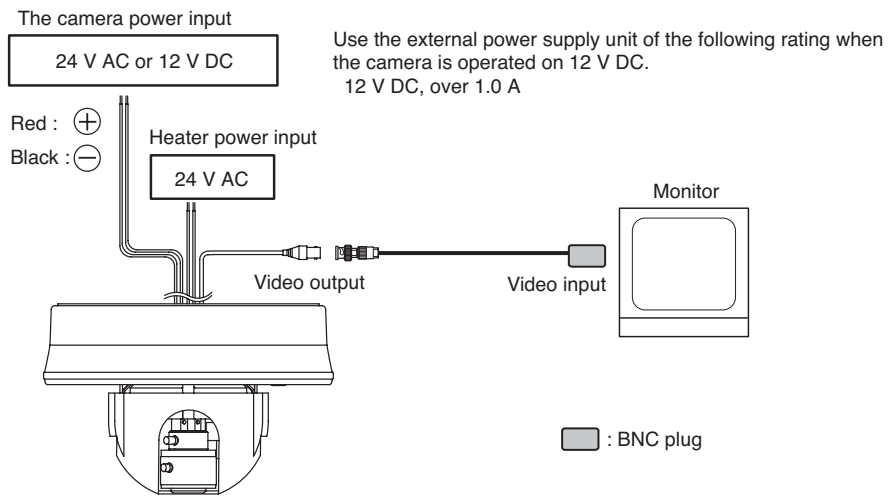

7. ADJUSTMENT

1. Switch on the camera power after completing camera connections.
The power is supplied to the camera.
2. Connect the monitor to the Monitor Output terminal to permit a picture to be viewed on the monitor.
3. Set the Flickerless switch to ON if light flicker is annoying.
Light flicker may interfere with the view under fluorescent lamps in the area where power frequency is 50 Hz (CU) or 60 Hz (CE). In such cases, set the Flickerless switch to "ON" position, and the image free from flickering can be obtained.

Note

If the Flickerless switch is set to the ON position, sensitivity is reduced compared to operation in the OFF position. When using the camera in a dark location, or where light flicker is not an annoyance, set the switch to the OFF position.

4. Adjust the camera angle.
Camera angle can be adjusted for up to $350^{\circ}(\pm 175^{\circ})$ for horizontal rotation and up to $160^{\circ}(\pm 80^{\circ})$ for vertical rotation, and tilt of camera images for up to $180^{\circ}(\pm 90^{\circ})$. To adjust horizontal rotation and vertical rotation, loosen each rotation lock screw.

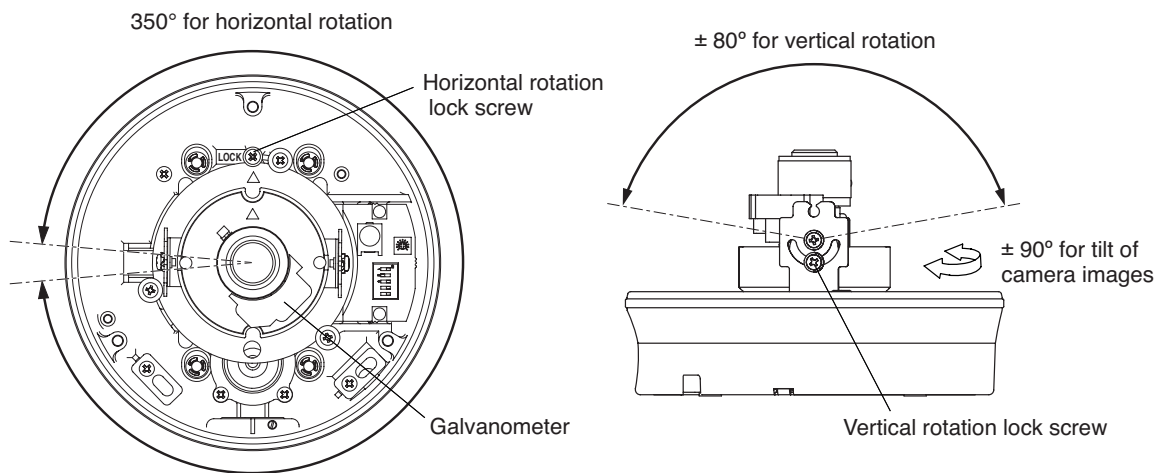

After angle adjustment completion, tighten both rotation lock screws.

5. Adjust the angle of view with the Zoom ring and adjust the focus with the Focus ring for the best possible picture reproduction.
After lens adjustment completion, tighten both the Zoom ring fixing screw and the Focus ring fixing screw.

Notes

- Since the Iris control (for sensitivity adjustment) is factory-preset to an optimum position for general use, avoid tampering with it in normal conditions. Turning the control unnecessarily could cause reduced picture quality or equipment failure. When the Iris control needs to be readjusted to match a specific subject, first set both the Focus adjustment switch and the Backlight compensation switch to the OFF position, then adjust the control to an optimum level. After adjustment, place a hand over the lens for several seconds and then release to check the lens for correct iris operation.
- If the focus is adjusted for a subject under good lighting conditions, the subject may go out of focus when conditions become dark. To avoid this, adjust the lens focus after setting the Focus adjustment switch to the ON position. Be sure to switch it back to the OFF position after completing lens adjustment.
- When adjusting the lens, do not touch the galvanometer.
- If the focus is adjusted for the Tele side, the subject may go out of focus when covering a dome cover. To avoid this, adjust the lens focus after while making the dome cover inverted in front of the lens.

6. After all adjustments completion, attach the inner cover and dome cover to the camera.

8. ABOUT THE MODE SETTING SWITCH

Set each switch to the position that provides the best picture reproduction.

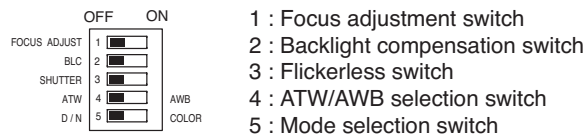

Mode Setting Switch
(Factory-preset setting)

8.1. Focus adjustment switch

Set this switch when adjusting the lens focus. (This setting provides the same effect as when using an ND filter.)

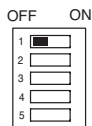

Standard position :

Set to OFF after lens adjustment completion. Set to this position during normal use.

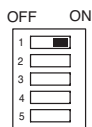

Focus adjustment position (during adjustment) :

Use this position when focusing the lens. If the focus is adjusted for a subject under good lighting conditions, the subject may go out of focus when conditions become dark. Set the Focus adjustment switch to ON only when performing focus adjustment.

Note: When the Focus adjustment switch is set to the "ON" position, the color of the screen may change periodically if the camera is used under fluorescent lighting. Further, the screen may flicker in areas where the electrical frequency is 50 Hz (CU) or 60 Hz (CE).

8.2. Backlight compensation switch

Set this switch so that the subject is not displayed in black when backlit.

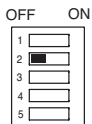

Standard position :

Set to this position during normal use. Backlight compensation function does not operate when the switch is set to this position.



Backlight Compensation position (when backlit) :

This position compensates images from being displayed in black when the image is backlit.

8.3. Flickerless switch

Set this switch to the ON position when annoying screen image flicker is detected.



Standard position :

Set to this position during normal use.

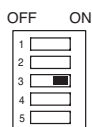

Flickerless :

Annoying screen flicker may result under fluorescent lighting in areas operating with a power frequency of 50 Hz (CU) or 60 Hz (CE). In such cases, set the Flickerless switch to the ON position to permit a flicker-free picture to be viewed.

Note: If the Flickerless switch is set to the ON position, sensitivity is reduced compared to operation in the OFF position. When using the camera in a dark location, or where light flicker is not an annoyance, set the switch to the OFF position.

8.4. ATW/AWB selection switch

Set the white balance operation.

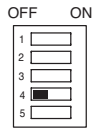

ATW:

Set to this position during normal use. The camera's white balance automatically changes as an object's color temperature varies.

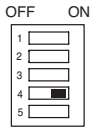

AWB:

Use this switch when the difference between the displayed color and actual color is annoying. Shoot the white object, then turn the switch ON. The camera operates on the initially set white balance even if an object's color temperature changes.

8.5. Mode selection switch

Set the operation when the object becomes dark.

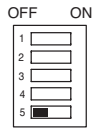

D/N:

The camera mode automatically switches from color to black-and-white operation when the object becomes dark.

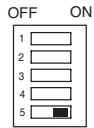

COLOR:

The camera mode does not switch to black-and-white operation even if the object becomes dark. The camera always generates color images.

9. TROUBLESHOOTING

Symptom	Possible Cause	Remedy
No camera image displayed on the monitor.	<ul style="list-style-type: none"> · Monitor TV's power is not switched ON. · Cables are not correctly connected. · BNC plugs are not correctly soldered. · Camera's power is not switched ON. 	<ul style="list-style-type: none"> · Switch on the main power. · Connect the cables correctly. · Solder BNC plugs correctly. · Switch on the main power.
Camera image is not clear.	<ul style="list-style-type: none"> · Camera lens does not focus properly. · Lens is dirty. · Image black level of the monitor is not correctly adjusted. 	<ul style="list-style-type: none"> · Adjust the focus properly. · Remove dirt on the lens. · Adjust the level correctly.
When the object becomes dark, it could be out of focus.	If the focus is adjusted for a subject under good lighting conditions, the subject may go out of focus when conditions become dark. (Effects of depth of field)	Focus the lens again after turning the Focus adjustment switch of the Mode switch to "ON" position. After adjustment completion, be sure to turn the Focus adjustment switch of the Mode switch to "OFF" position.
The color of the camera image changes periodically.	The Focus adjustment switch is set to "ON."	Set the adjustment switch to "OFF."
The screen flickers even when the flickerless switch is set to "ON."	The Focus adjustment switch is set to "ON."	Set the adjustment switch to "OFF."

10. SPECIFICATIONS

Model No.	C-CV854D-3 (CU)	C-CV854D-9 (CU)
Power Source	For camera: 24 V AC, 50/60 Hz or 12 V DC For Heater: 24 V AC, 50/60 Hz	
Power Consumption	4 W (300 mA, maximum current: 800 mA)	
Image Device	1/3 type IT-CCD	
Number of Effective Pixels	771 (H) x 492 (V), 380,000 pixels	
Scanning System	2:1 interlace	
Scanning Frequency	Horizontal: 15.734 kHz , Vertical: 59.94 Hz	
Monitor Output	VBS1.0 V(p-p), 75 Ω, RCA pin jack	
Video Output	VBS1.0 V(p-p), 75 Ω, BNC-R jack	
Synchronizing System	Internal synchronization	
Resolution (at center)	Horizontal: 540 lines, Vertical: 350 lines	Horizontal: 480 lines, Vertical: 350 lines
S/N Ratio	50 dB	
Minimum Illumination (Flickerless: OFF)	0.5 lx (50 IRE, color operation), 0.1 lx (20 IRE, color operation), 0.05 lx (50 IRE, black and white operation, incandescent lamp)	
Threshold illumination for mode switching	Color-to-B/W mode: Approx. 5 lx B/W-to-color mode: Approx. 25 lx (incandescent lamp)	
White Balance Mode	ATW/AWB (switch selector)	
Focal Length	f=3.0 mm – 9.0 mm	f=9.0 mm – 22.0 mm
Maximum Aperture Ratio	1:1.4 – 2.4	1:1.5 – 2.9
Iris	Auto-iris	
Angle of View	Horizontal: 90.3°– 31.9°, Vertical: 66.4°– 23.9°	Horizontal: 30.6°– 13.0°, Vertical: 22.6°– 9.8°
Adjustment Switch	ON/OFF (used for focus adjustment)	
Day/Night Mode	Automatic/Off (switch selector)	
Other Functions	Backlight compensation, Shutter speed, Iris control, Max. 4 x sensitivity increase (auto), Noise reduction	
Water/Dust Protection	IP66	
Operating Temperature	– 10°C to + 50°C (14°F to 122°F) (When an optional heater unit is attached: – 30°C to + 50°C (– 22°F to 122°F))	
Operating Humidity	90% RH or less (no condensation)	
Applications	Outdoor/Indoor use	
Finish	Case, bezel : Die-cast Aluminum, light gray, paint, Dome cover : PC resin (transparent)	
Dimensions	ø154.2 x 110 (H) mm (ø6.07 x 4.33 (H) inch) (excluding the cables)	
Weight	1.1 kg (2.43 lb)	

The design and specifications are subject to change without notice for improvement.

Note

No camera mounting screws are supplied. For mounting, use screws of 4 x 25 mm (0.16" x 0.98") or longer.

Model No.	C-CV854D-3 (CE)
Power Source	For camera: 24 V AC, 50/60 Hz, or 12 V DC For Heater: 24 V AC, 50/60 Hz
Power Consumption	4 W (300 mA, maximum current: 800 mA)
Image Device	1/3 type IT-CCD
Number of Effective Pixels	752 (H) x 582 (V), 440,000 pixels
Scanning System	2:1 interlace
Scanning Frequency	Horizontal: 15.625 kHz, Vertical: 50 Hz
Monitor Output	VBS1.0 V(p-p), 75 Ω, RCA pin jack
Video Output	VBS1.0 V(p-p), 75 Ω, BNC-R jack
Synchronizing System	Internal synchronization
Resolution (at center)	Horizontal: 500 lines , Vertical: 410 lines
S/N Ratio	50 dB
Minimum Illumination (Flickerless: OFF)	0.5 lx (350 mV, color operation), 0.1 lx (140 mV, color operation), 0.05 lx (350 mV, black and white operation, incandescent lamp)
Threshold illumination for mode switching	Color-to-B/W mode: Approx. 5 lx B/W-to-color mode: Approx. 25 lx (incandescent lamp)
White Balance Mode	ATW/AWB (switch selector)
Focal Length	f=3.0 mm – 9.0 mm
Maximum Aperture Ratio	1:1.4 – 2.4
Iris	Auto-iris
Angle of View	Horizontal: 90.3°– 31.9°, Vertical: 66.4°– 23.9°
Adjustment Switch	ON/OFF (used for focus adjustment)
Day/Night Mode	Automatic/Off (switch selector)
Other Functions	Backlight compensation, Shutter speed, Iris control, Max. 4 x sensitivity increase (auto), Noise reduction
Water/Dust Protection	IP66
Operating Temperature	– 10°C to + 50°C (14°F to 122°F) (When an optional heater unit is attached: – 30°C to + 50°C (– 22°F to 122°F))
Operating Humidity	90% RH or less (no condensation)
Applications	Outdoor/Indoor use
Finish	Case, bezel : Die-cast Aluminum, light gray, paint Dome cover : PC resin (transparent)
Dimensions	ø154.2 x 110 (H) mm (ø6.07 x 4.33 (H) inch) (excluding the cables)
Weight	1.1 kg (2.43 lb)

The design and specifications are subject to change without notice for improvement.

Note

No camera mounting screws are supplied. For mounting, use screws of 4 x 25 mm (0.16" x 0.98") or longer.

• Accessories

L-type wrench 1
Base gasket 1

• Optional products

Heater unit: C-A854H
Flush ceiling mounting bracket: C-BC850U
Wall mounting bracket: C-BC850W