

## PENDANT SPEAKERS

### PE-64 PE-304

Thank you for purchasing TOA's Pendant Speakers. Please carefully follow the instructions in this manual to ensure long, trouble-free use of your equipment.

#### 1. SAFETY PRECAUTIONS

- Before installation or use, be sure to carefully read all the instructions in this section for correct and safe operation.
- Be sure to follow all the precautionary instructions in this section, which contain important warnings and/or cautions regarding safety.
- After reading, keep this manual handy for future reference.

#### **WARNING**

Indicates a potentially hazardous situation which, if mishandled, could result in death or serious personal injury.

- Install the unit only in a location that can structurally support the weight of the unit and the mounting bracket. Doing otherwise may result in the unit falling down and causing personal injury and/or property damage.

#### 3. SPECIFICATIONS

Model No.	PE-64	PE-304
Enclosure	Bass-reflex type	
Rated Input	6 W (100 V line), 3 W (70 V line)	30 W (100 V, 70 V line, 8 Ω)
Rated Impedance	Low	8 Ω
	100 V line	330 Ω (30 W), 500 Ω (20 W), 670 Ω (15 W), 1 kΩ (10 W), 2 kΩ (5 W)
	70 V line	170 Ω (30 W), 250 Ω (20 W), 330 Ω (15 W), 500 Ω (10 W), 1 kΩ (5 W)
Sensitivity (500 – 5,000 Hz, pink noise)	90 dB (1 W, 1 m)	91 dB (1 W, 1 m)
Frequency Response	100 – 18,000 Hz (at 20 dB below peak)	70 – 20,000 Hz (at 20 dB below peak)
Speaker Component	12 cm (5") cone type	12 cm (5") cone type + balanced dome-tweeter
Speaker Cord	2-core cabtyre cord 5 m (16.4 ft)	
Application Cable	600 V vinyl-insulated cable (IV wire or HIV wire) Solid wire: $\phi 0.8 - \phi 1.6$ mm (equivalent to AWG 20 – 14) 7-core twisted wire: 0.75 – 1.25 mm <sup>2</sup> (equivalent to AWG 18 – 16)	
Connection	Push-in connector (bridging terminal of 2 branch type)	
Finish	Enclosure: HIPS resin, off white (RAL 9010 or equivalent color) Grille: Surface-treated steel plate net, off white (RAL 9010 or equivalent color), paint	
Dimensions (unit only)	$\phi 186 \times 251$ (h) mm ( $\phi 7.32'' \times 9.88''$ )	
Weight (unit only)	1.5 kg (3.31 lb)	2.1 kg (4.63 lb)
Accessories	Ceiling bracket ..... 1, Mounting hanger ..... 1, Ceiling cover ..... 1, Tapping screw 4 x 16 ..... 4	

**Note:** The design and specifications are subject to change without notice for improvement.

- Do not use other methods than specified to mount the bracket. Extreme force is applied to the unit and the unit could fall off, possibly resulting in personal injuries.
- Tighten all screws securely. If any is loosely fixed, this may cause the unit to fall, resulting in personal injury.

#### **CAUTION**

Indicates a potentially hazardous situation which, if mishandled, could result in moderate or minor personal injury, and/or property damage.

- To avoid electric shocks, be sure to switch off the amplifier's power when connecting speakers.
- Do not operate the unit for an extended period of time with the sound distorting. This is an indication of a malfunction, which in turn can cause heat to generate and result in a fire.
- Do not hang down from the unit as this may cause it to fall down or drop, resulting in personal injury and/or property damage.

#### 2. GENERAL DESCRIPTION

The PE-64 and PE-304 are pendant speakers designed for ceiling suspension installations.

Considered in architectural design, they can blend in with lighting equipment.

A directly-attached 5 m (16.4 ft) speaker cord allows the speaker to be suspended from the high ceiling.

The PE-64 is driven on high-impedance (100 V and 70 V) line, while the PE-304 is driven on both high-impedance (100 V and 70 V) and low-impedance (8 Ω) lines.

The input power (impedance) can be easily changed at the upper side of the speaker.

The speakers are easy to repaint so as to meet a wide range of design needs.

## 4. WIRING DIAGRAMS

### 4.1. PE-64

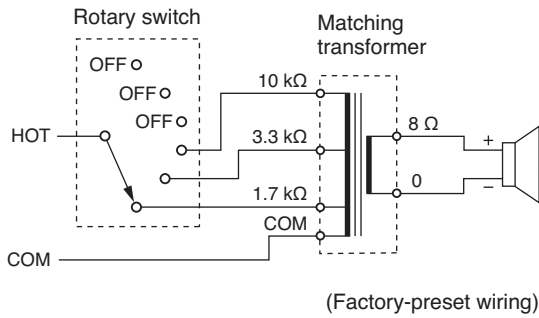

### 4.2. PE-304

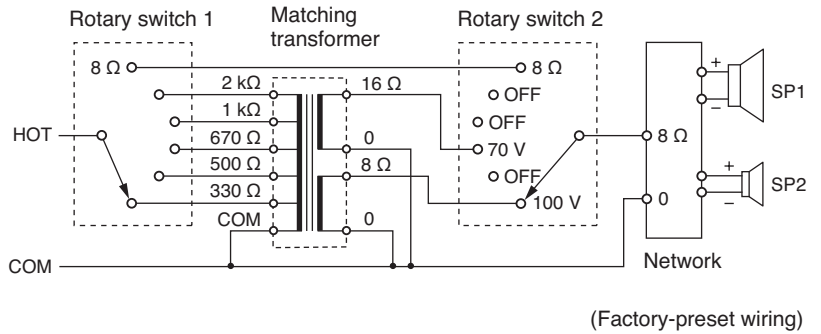

## 5. INPUT POWER (IMPEDANCE) CHANGE

### Important

Be sure to follow the instructions below. Failure to do so may cause damage to the speaker.

- Switch off the amplifier's power when changing the input power.
- Never make 8 Ω connection in a 100 V or 70 V line system, as excessive input power is applied to the speaker, possibly resulting in damage. (PE-304 only)

### 5.1. PE-64

The input power (impedance) is factory-preset to 6 W (1.7 kΩ) for 100 V line and 3 W (1.7 kΩ) for 70 V line. When changing this setting, use a standard screwdriver to rotate the rotary switch on the upper side of the speaker to the desired position

Impedance	1.7 kΩ	3.3 kΩ	10 kΩ
100 V line	6 W	3 W	1 W
70 V line	3 W	1.5 W	0.5 W

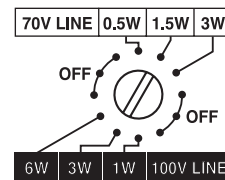

### Note

Shown above is an example when the input power is set to 3 W on 100 V line and 1.5 W on 70 V line.

### 5.2. PE-304

The input power (impedance) is factory-preset to 30 W (330 Ω) for 100 V line. When changing this setting, use a standard screwdriver to rotate the rotary switches on the upper side of the speaker to the desired position.

Input power	30 W	20 W	15 W	10 W	5 W
100 V line	330 Ω	500 Ω	670 Ω	1 kΩ	2 kΩ
70 V line	170 Ω	250 Ω	330 Ω	500 Ω	1 kΩ

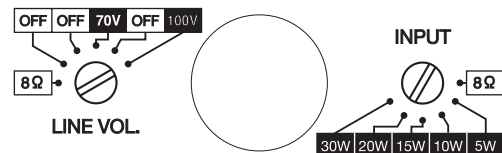

### Note

Shown above is an example when the input power is set to 20 W on 100 V line.

- (1) When operating at high impedance (100 V and 70 V lines);  
Set the rotary switch of "LINE VOL." to "100 V" or "70 V" and that of "INPUT" to the input power to be used.
- (2) When operating at low impedance;  
Set both rotary switches of "LINE VOL." and "INPUT" to 8 Ω.

## 6. INSTALLATION

**Step 1.** Secure the ceiling bracket to the ceiling with 4 screws.  
Pull both the lead-in and lead-out cables through the cable hole in the bracket.

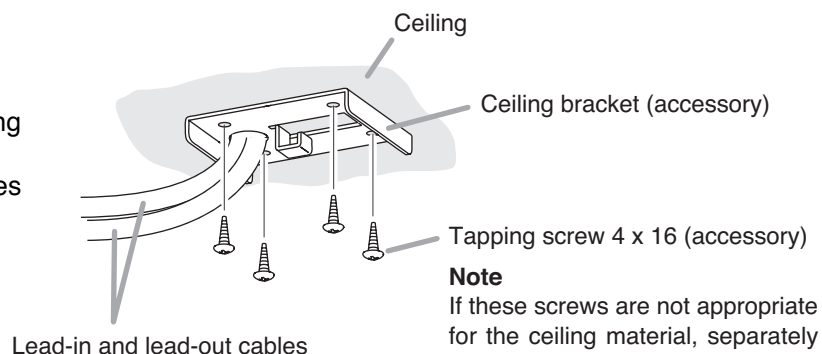

### Note

If these screws are not appropriate for the ceiling material, separately prepare the proper screws.

**Step 2.** Pass the speaker cord through the supplied ceiling cover, and cut the cord to the desired length.

**Note:** Strip the end of speaker cord as illustrated.

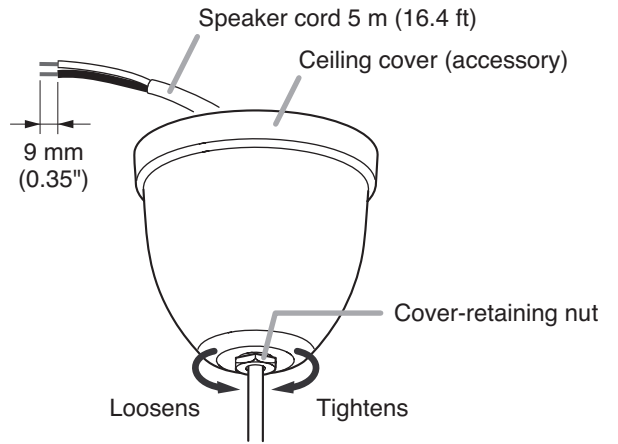

**Step 3.** Run the speaker's cable through the cable holes in the mounting hanger, then connect it to the input connector.

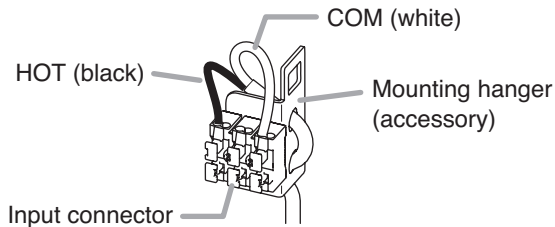

**Step 4.** Put the mounting hanger onto the ceiling bracket's hook.

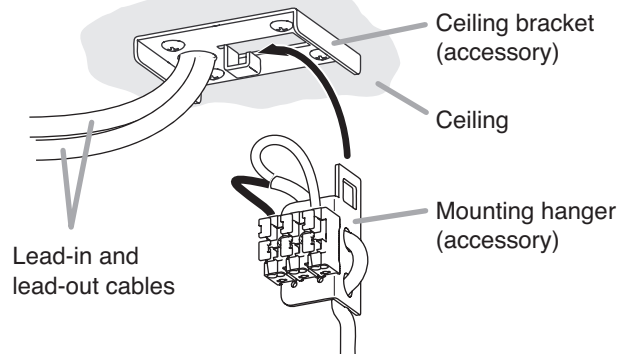

**Step 5.** Connect both the lead-in and lead-out cables to the input connector.

[Applicable cable]

- Solid wire:  $\varnothing 0.8 - \varnothing 1.6$  mm (equivalent to AWG 20 – 14)
- Stranded wire (7-core):  $0.75 - 1.25$  mm<sup>2</sup> (equivalent to AWG 18 – 16)

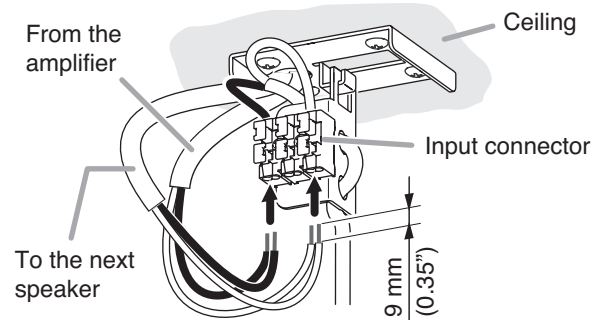

**Step 6.** Push the ceiling cover, slipped over the cord in Step 2, onto the ceiling surface, then tighten the cover-retaining nut using a 17 mm (0.67") hex wrench. In the case of exposed wiring, notch the cable entry tab on the rim of the cover, then make connections.

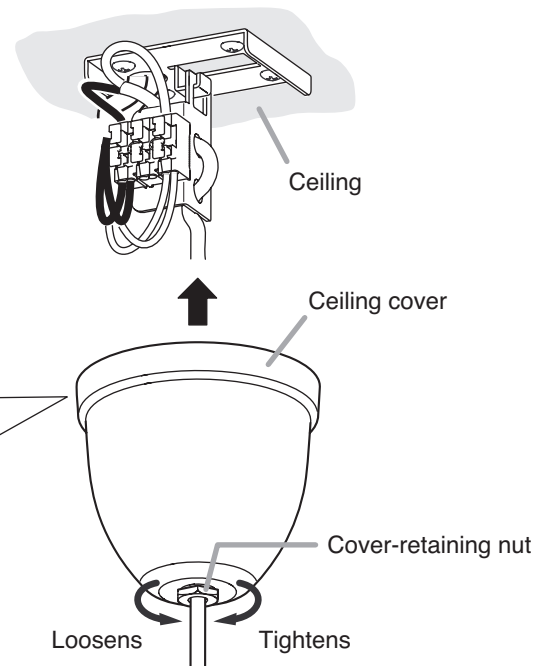
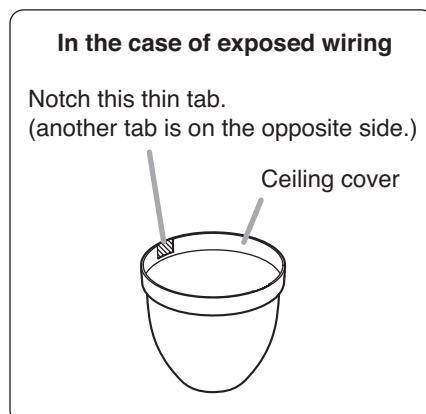
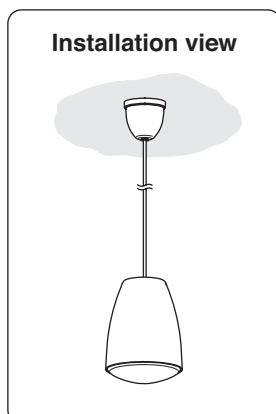

## 7. REPAINTING THE SPEAKER

Follow the procedure below when repainting the speaker cover and mesh net.

**Note:** Never touch the inner speaker diaphragm during work.

**Step 1.** Remove 4 screws on the upper side of the speaker cover to detach the cover.

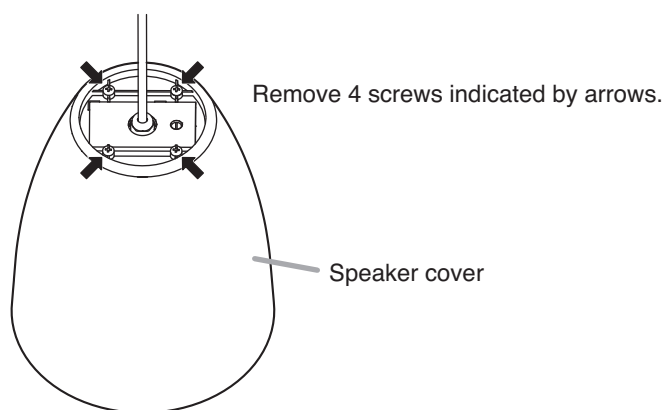

**Step 2.** Remove 3 screws that fix the mesh net, then raise the turndown tabs of the mesh net to detach.

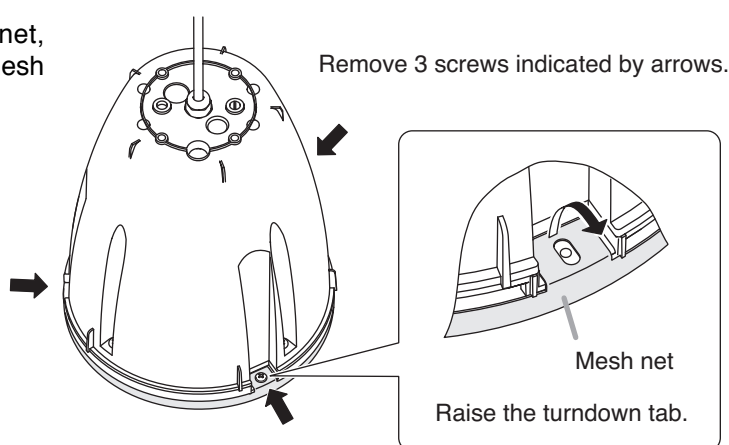

**Step 3.** Clean the speaker cover and mesh net.  
Wipe with a soft cloth damped in a detergent.

**Note**

Do not use thinner or other volatile liquids to clean them as doing so may cause deformation.

**Step 4.** Use spray paint to apply uniform and thin coat of paint.

**Notes**

- Avoid painting with a roller or brush, as the mesh net could become clogged with paint.
- Use appropriate paints for the speaker cover and mesh net materials.
  - Speaker cover: Fire-resistant HIPS resin
  - Mesh net: Rolled steel plate (acrylic paint)

**Step 5.** After the paint has dried, apply another light coat.  
Repeating Step 4, apply 2 or more light coats of paint. Application of one thick coat of paint all at once may cause drips or unevenness to show up in the painted finish, or clog the mesh holes.

**Step 6.** After the paint has dried, replace the speaker cover and mesh net.

### Traceability Information for Europe

Manufacturer:  
TOA Corporation  
7-2-1, Minatojima-Nakamachi, Chuo-ku, Kobe, Hyogo,  
Japan

Authorized representative:  
TOA Electronics Europe GmbH  
Suederstrasse 282, 20537 Hamburg,  
Germany

