

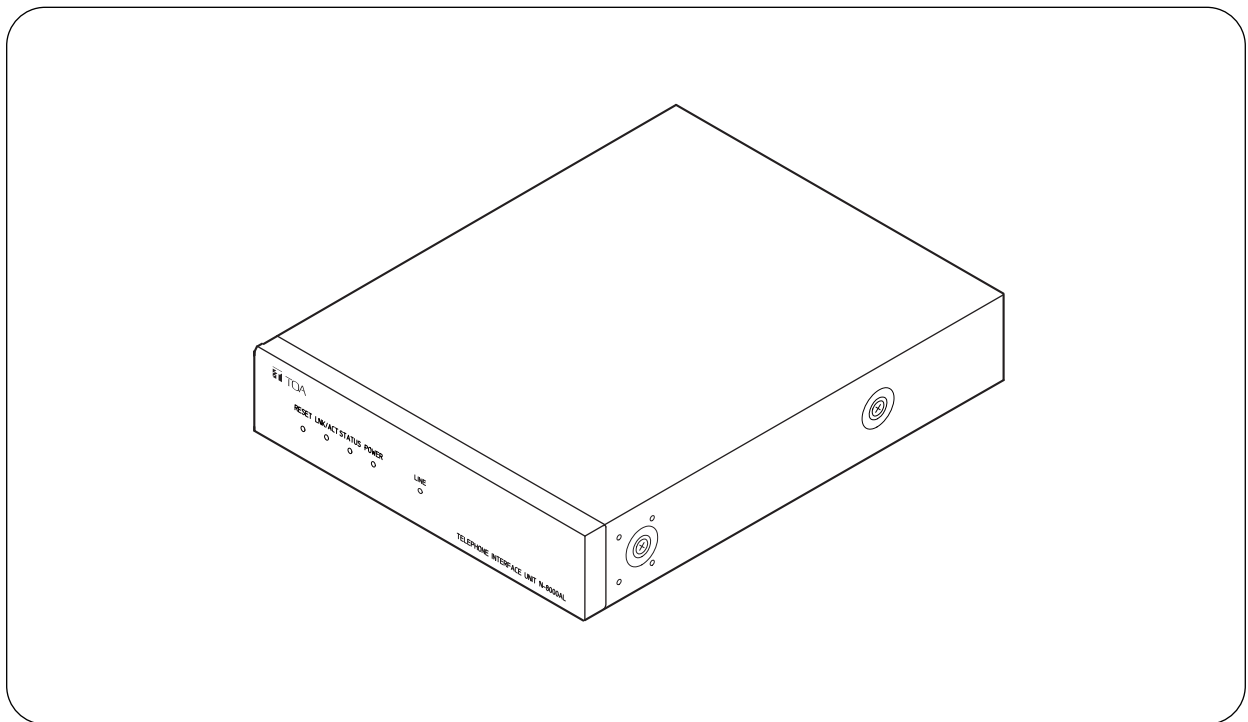

INSTALLATION MANUAL

# IP INTERCOM TELEPHONE INTERFACE UNIT

## N-8000AL



Thank you for purchasing TOA's IP Intercom Telephone interface unit.  
Please carefully follow the instructions in this manual to ensure long, trouble-free use of your equipment.

TOA Corporation

# TABLE OF CONTENTS

<b>1. SAFETY PRECAUTIONS</b> .....	3
<b>2. GENERAL DESCRIPTION</b> .....	4
<b>3. FEATURES</b> .....	4
<b>4. NOMENCLATURE AND FUNCTIONS</b>	
Front .....	5
Rear .....	5
<b>5. INSTALLATION</b>	
5.1. Equipment Rack Mounting	
5.1.1. Setting space .....	6
5.1.2. Mounting on the rack .....	7
5.2. Desk-Top Installation .....	8
5.3. Wall Mounting .....	8
<b>6. WIRING</b>	
6.1. Connection Diagram .....	10
6.2. Type of Cable .....	11
6.3. Connector Connection .....	11
<b>7. ACCESSORIES</b> .....	12
<b>8. OPTIONAL PRODUCTS</b> .....	12

# 1. SAFETY PRECAUTIONS

- Before installation or use, be sure to carefully read all the instructions in this section for correct and safe operation.
- Be sure to follow all the precautionary instructions in this section, which contain important warnings and/or cautions regarding safety.
- After reading, keep this manual handy for future reference.
- These servicing instructions are for use by qualified personnel only. Do not perform any servicing in the installation manual unless you are qualified to do so.

## Safety Symbol and Message Conventions

Safety symbols and messages described below are used in this manual to prevent bodily injury and property damage which could result from mishandling. Before operating your product, read this manual first and understand the safety symbols and messages so you are thoroughly aware of the potential safety hazards.



### WARNING

Indicates a potentially hazardous situation which, if mishandled, could result in death or serious personal injury.



### CAUTION

Indicates a potentially hazardous situation which, if mishandled, could result in moderate or minor personal injury, and/or property damage.



### WARNING

#### When Installing the Unit

- Do not expose the unit to rain or an environment where it may be splashed by water or other liquids, as doing so may result in fire or electric shock.
- Use the unit only with the voltage specified on the unit. Using a voltage higher than that which is specified may result in fire or electric shock.
- Do not cut, kink, otherwise damage nor modify the power supply cord. In addition, avoid using the power cord in close proximity to heaters, and never place heavy objects -- including the unit itself -- on the power cord, as doing so may result in fire or electric shock.
- Avoid installing or mounting the unit in unstable locations, such as on a rickety table or a slanted surface. Doing so may result in the unit falling down and causing personal injury and/or property damage.
- Install the unit only in a location that can structurally support the weight of the unit and the mounting bracket. Doing otherwise may result in the unit falling down and causing personal injury and/or property damage.

#### When the Unit is in Use

- Should the following irregularity be found during use, immediately disconnect the power supply plug from the AC outlet and contact your nearest TOA dealer. Make no further attempt to operate the unit in this condition as this may cause fire or electric shock.

- If you detect smoke or a strange smell coming from the unit
- If water or any metallic object gets into the unit
- If the power supply cord is damaged (exposure of the core, disconnection, etc.)
- If it is malfunctioning (no tone sounds.)

- To prevent a fire or electric shock, never open nor remove the unit case as there are high voltage components inside the unit. Refer all servicing to qualified service personnel.
- Do not insert nor drop metallic objects or flammable materials in the ventilation slots of the unit's cover, as this may result in fire or electric shock.
- Do not touch a plug during thunder and lightning, as this may result in electric shock.



### CAUTION

#### When Installing the Unit

- Never plug in nor remove the power supply plug with wet hands, as doing so may cause electric shock.
- When unplugging the power supply cord, be sure to grasp the power supply plug; never pull on the cord itself. Operating the unit with a damaged power supply cord may cause a fire or electric shock.
- Be sure to follow the instructions below when rack-mounting the unit. Failure to do so may cause a fire or personal injury.
  - Install the equipment rack on a stable, hard floor. Fix it with anchor bolts or take other arrangements to prevent it from falling down.

- When connecting the unit's power cord to an AC outlet, use the AC outlet with current capacity allowable to the unit.
- The supplied rack-mounting screws can be used for the TOA equipment rack only. Do not use them for other racks.

#### **When the Unit is in Use**

- Do not place heavy objects on the unit as this may cause it to fall or break which may result in personal injury and/or property damage. In addition, the object itself may fall off and cause injury and/or damage.
- Do not stand or sit on, nor hang down from the unit as this may cause it to fall down or drop, resulting in personal injury and/or property damage.

## **2. GENERAL DESCRIPTION**

TOA's N-8000AL is Telephone interface unit used for the N-8000 Series Packet Intercom System (IP network compatible intercom) employing packet audio technology\*<sup>1</sup>.

It has a single telephone line interface, allowing an analog telephone to be connected.

Connecting the unit to the LAN permits the analog telephone to be operated in the same manner as the intercom master station.

\*<sup>1</sup> Technology related to audio transmission over a network.

#### **Warning**

This is a class A product. In a domestic environment this product may cause radio interference in which case the user may be required to take adequate measures.

## **3. FEATURES**

- Exchanges, IP stations and various kinds of interface units can be distributed over a data communications network.
- Can be connected to an existing local area network (LAN) or wide-area network (WAN).
- The dedicated software program enables centralized control with a personal computer.
- System maintenance (verifying operation log and Line supervision) can also be performed with a personal computer and Internet browser.

## 4. NOMENCLATURE AND FUNCTIONS

### [Front]

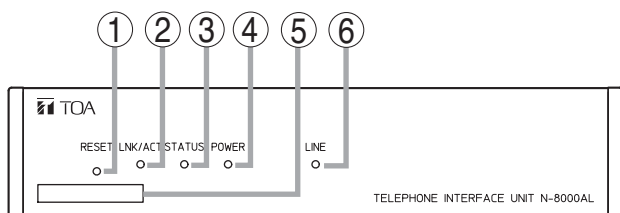

#### 1. Reset key [RESET]

Pressing this key reactivates this unit.

#### 2. LNK/ACT indicator [LNK/ACT] (Green)

Lights when connected to a network, and flashes while transmitting or receiving data.

#### 3. Status indicator [STATUS] (Red)

Continuously lights while data is written to an internal storage medium (FlashMemory). Flashes if there is a failure.

#### 4. Power indicator [POWER] (Green)

Lights when power is supplied to the unit.

#### 5. MAC address

This is the address\*<sup>1</sup> used by the unit. Since the relationship of each exchange location to its MAC address is established when setting the network attributes, keep track of this relationship for later use.

\*<sup>1</sup> The inherent address assigned to each network component, expressed in 12-digit hexadecimal notation.

#### 6. Line indicator [LINE] (Green)

Lights when the connected telephone is off-hook.

### [Rear]

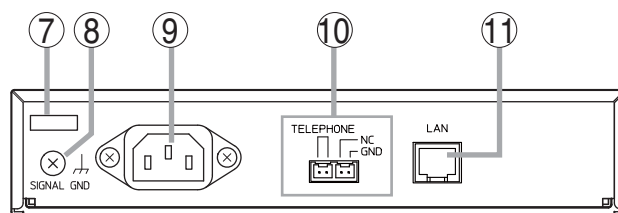

#### 7. Cord clamp

Pass the power cord through this clamp to ensure that the plug does not pull out when the unit is mounted to a wall. (Refer to p. 9.)

#### 8. Functional earth terminal [SIGNAL GND]

Ground this terminal.

**Note:** This terminal is not for protective earth.

#### 9. AC inlet

Connect the supplied power cord.

#### **Note**

If there is a danger of lightning strikes, insert an appropriate surge arrester into the power line.

#### 10. Telephone connection terminal [TELEPHONE]

Connect a telephone to this terminal using one pair of twisted pair cables.

Use the mini-clamp connector for connection of this terminal.

(Refer to p. 11.)

#### 11. Network connection terminal [10/100M]

Connects to a 10BASE-T- or 100BASE-TX-compatible network. (Ethernet RJ-45 jack)

## 5. INSTALLATION

The N-8000AL can be installed in any of three ways: (1) equipment rack mounting, (2) wall mounting, and (3) desk-top installation.

### 5.1. Equipment Rack Mounting

- A) Elevated Operating Ambient - If installed in a closed or multi-unit rack assembly, the operating ambient temperature of the rack environment may be greater than room ambient. Therefore, consideration should be given to installing the equipment in an environment compatible with the maximum ambient temperature (T<sub>ma</sub>) specified by the manufacturer.
- B) Reduced Air Flow - Installation of the equipment in a rack should be such that the amount of air flow required for safe operation of the equipment is not compromised.
- C) Mechanical Loading - Mounting of the equipment in the rack should be such that a hazardous condition is not achieved due to uneven mechanical loading.
- D) Circuit Overloading - Consideration should be given to the connection of the equipment to the supply circuit and the effect that overloading of the circuits might have on overcurrent protection and supply wiring. Appropriate consideration of equipment nameplate ratings should be used when addressing this concern.
- E) Reliable Earthing - Reliable earthing of rack-mounted equipment should be maintained. Particular attention should be given to supply connections other than direct connections to the branch circuit (e.g. use of power strips)."

The N-8000AL can be mounted on the CR -273 or CR -413 or standard EIA 19" Equipment rack.  
For the CR -273 and CR -413 Equipment rack assembly, read the installation manual supplied with the rack.

#### Note

When installing the N-8000AL, lay the equipment rack down face-up to do installation work safely.

#### 5.1.1. Setting space

For maintenance works, allow much space between the wall and Equipment rack.

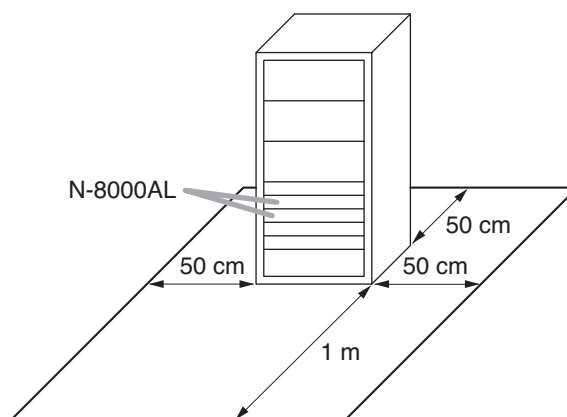

### 5.1.2. Mounting on the rack

Use the optional mounting hardware set when installing the unit in an equipment rack.

- Use the optional **MB-15B-BK hardware set** when mounting a single unit.

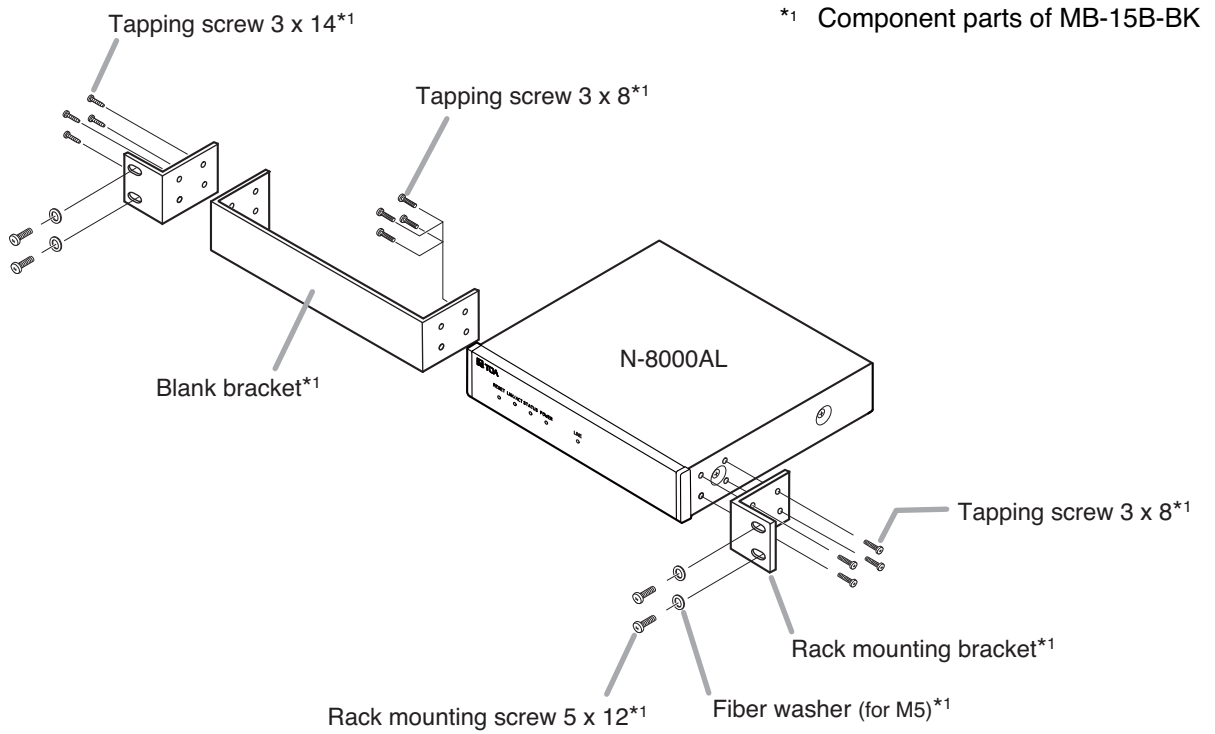

- Use the optional **MB-15B-J hardware set** when mounting 2 units.

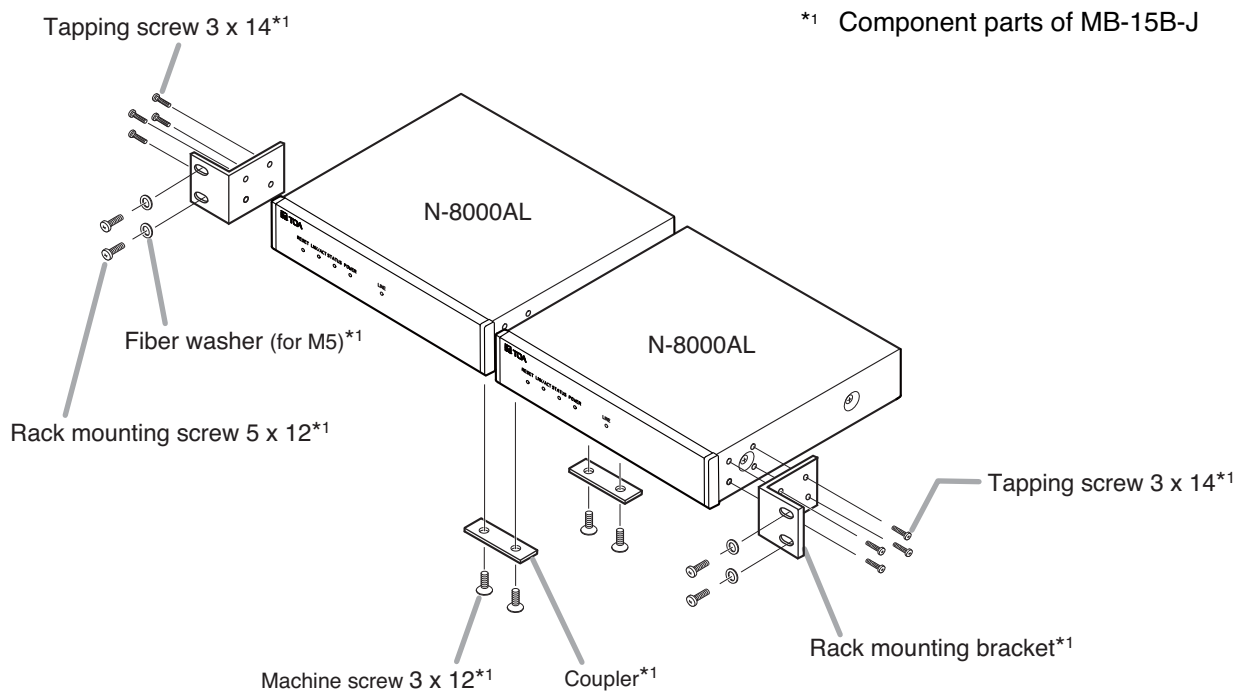

## 5.2. Desk-Top Installation

When installing the N-8000AL on a desk, secure the supplied plastic feet to the unit's bottom using the supplied machine screws.

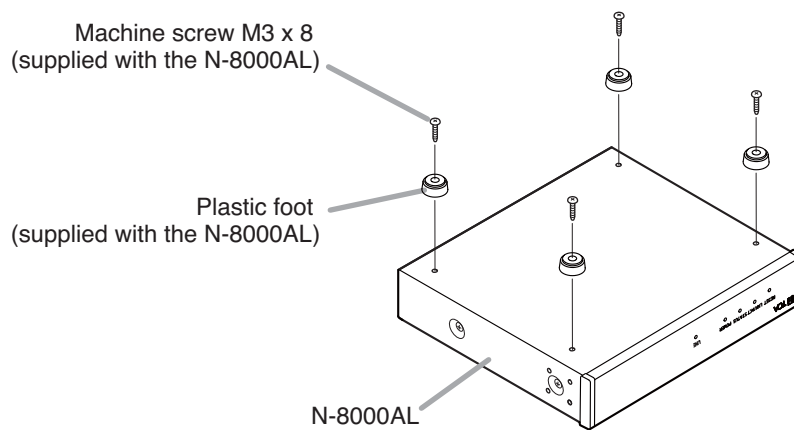

## 5.3. Wall Mounting

**Step 1.** The N-8000AL can be mounted on a wall using an optional YC-850 Wall-mounting bracket .  
Install the YC-850 to the N-8000AL.

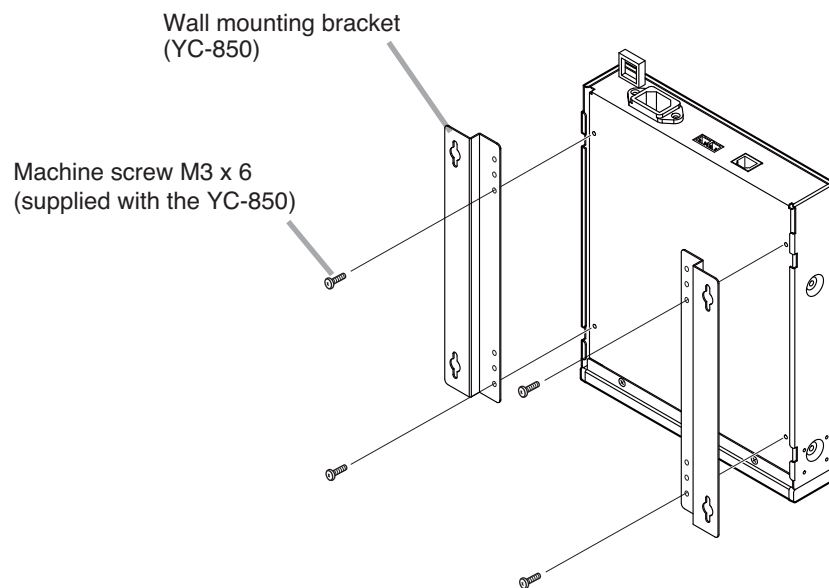



**Step 2.** Mount the N-8000AL on the wall.

**Notes**

- Use appropriate screws for the construction of wall.
- Wood screws 3.5 x 20 are supplied with the YC-850.
- The socket-outlet shall be installed near the equipment and the plug (disconnecting device) shall be easily accessible.

**Protect against disconnection  
(Power supply plug)**

Unlock cord clamp and run the power supply cord through it.

**Note**

Keep the cable length between a power supply plug and cord clamp as short as possible.

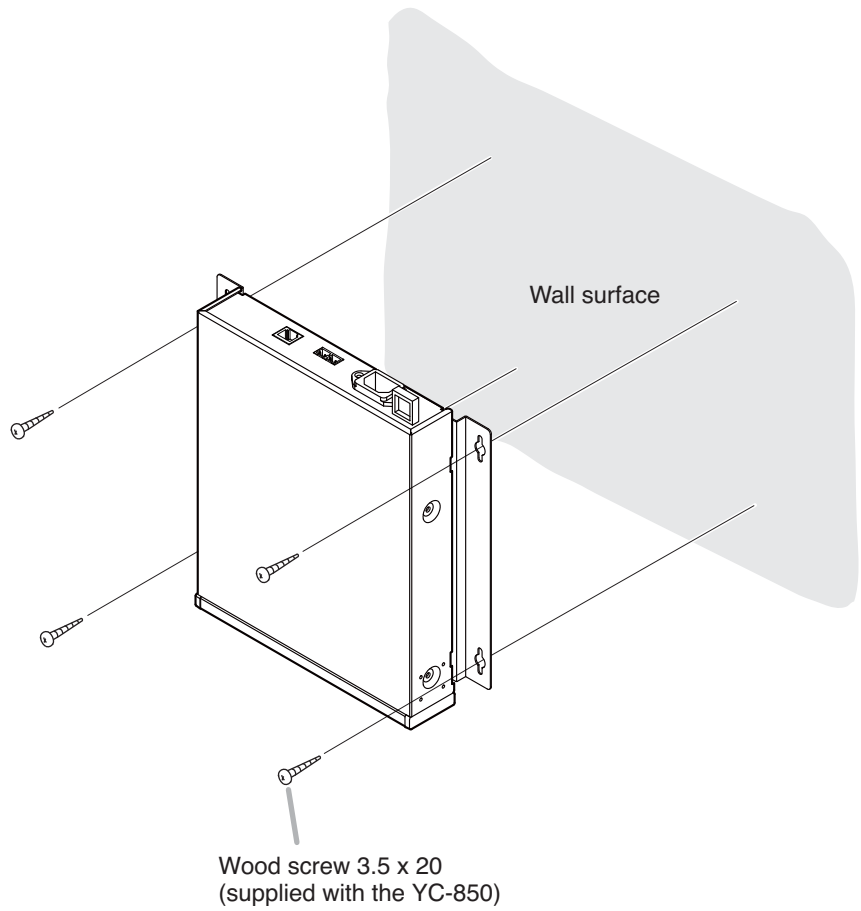
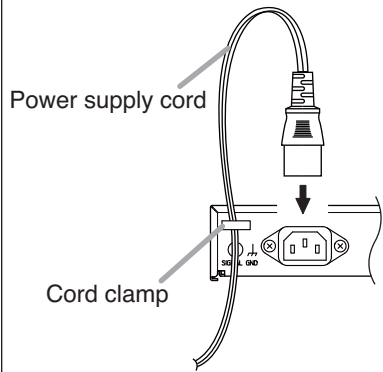

## 6. WIRING

### 6.1. Connection Diagram

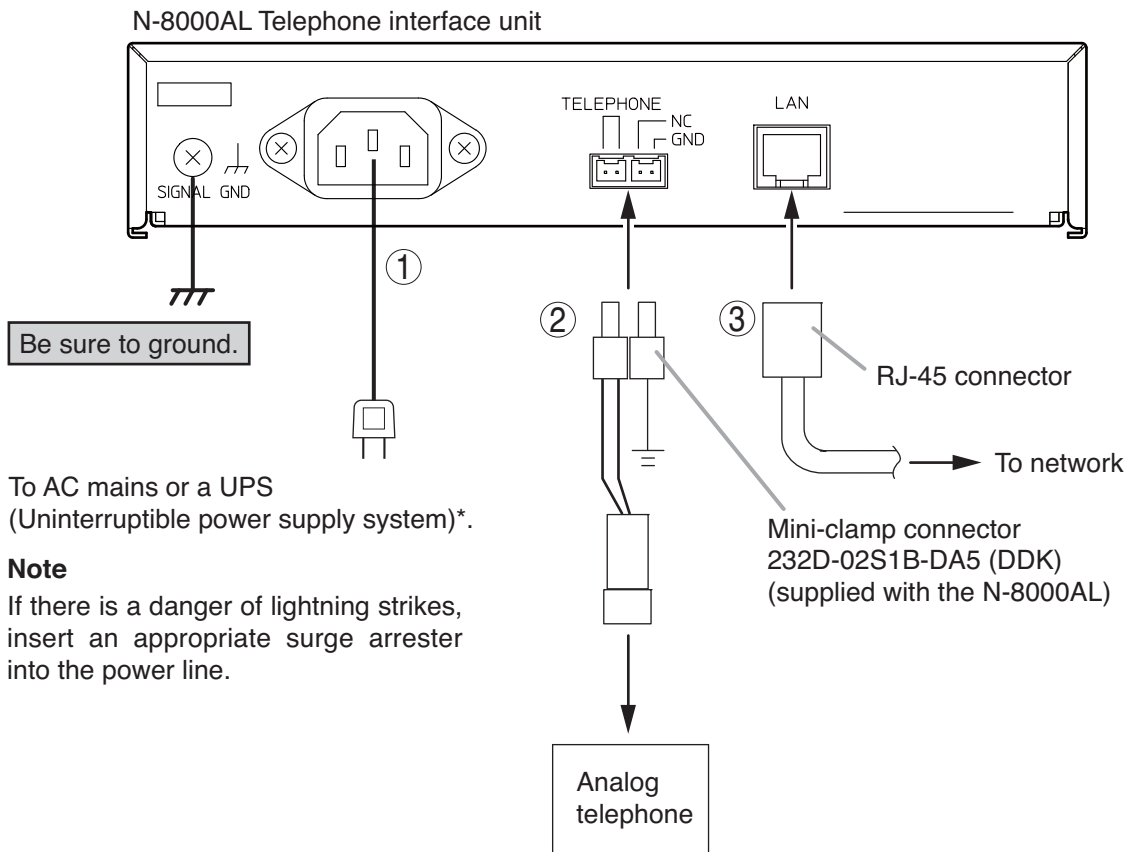

#### [General description of connection]

For cables, refer to p. 11.

#### 1. Power supply connection

Connect the supplied power supply cord to AC Mains or a UPS (Uninterruptible power supply).

#### About power supply cord handling

The supplied power supply cord is designed for exclusive use with the N-8000AL.  
Use the supplied power supply cord only with the N-8000AL.

#### 2. Telephone connection

Connect the unit to the telephones certified in the country where the unit is used.  
(Refer to p. 11, Connector connection.)

#### 3. Network connection

Can be connected to a network of 10BASE-T/100BASE-TX in auto-sensing.  
Use a straight through cable of UTP category 5 or more for this connection.

#### Notes

- The apparatus shall be connected to a main socket outlet with a protective earthing connection.
- Do not defeat the Class I product's earthed connections.
- The interconnected telecommunication terminal equipment (via "TELEPHONE"-connector of N-8000AL) should be UL Listed and the connections shall be made in accordance with Article 800 of the NEC. (CU version)
- The interconnected telecommunication terminal equipment (via "TELEPHONE"-connector of N-8000AL) should comply with IEC60950-1. (CE version)

\* Select an appropriate UPS taking into consideration the total power consumption of all system components and the required backup time, and also the requirement that the UPS should employ the on-line power system.

#### Reference

Telephone interface unit: 7 W (rated) for CE version, 7 W (rated) for CU version  
8-Port 10M/100M Switching Hub: 10W (Differs depending on products.)

## 6.2. Type of Cable

The types of cables are to be determined according to the following conditions.

- UTP category 5 Straight through cables with RJ45 connector are to be used for connecting to IP network.
- The number of cables pairs laid should be determined considering the possibility of future expansion of the system.
- Outdoor wires should be used where wiring passes through inaccessible areas such as ceilings or under floors where the maintenance is not performed. Indoor wires may also be used, however, in case where there is no risk of deterioration due to exposure to heat, etc.

### Note

Specifications related to junction are as follows.

Mini-clamp connector (N-8000AL Telephone connection terminal)

Conductor diameter:  $\varnothing$  0.4 – 0.65 mm (AWG22 – 26), Solid wire

Outside diameter:  $\varnothing$  1.05 mm or below

## 6.3. Connector Connection

Connect the mini-clamp connector supplied with the N-8000EX,N-8010EX,N-8000MI,N-8000CO,N-8000AL to a cable using a commercially available tool (pliers).

**Step 1.** Cut off two-cable ends in equal length, and insert them securely to a cover section (transparent side) of the mini-clamp connector.

### Note

Insert the cable without stripping the cable jacket.  
For cables, refer to p. 3-50, Type of Cable.

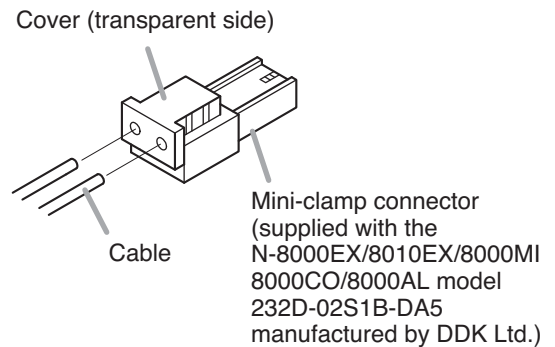

**Step 2.** With a pair of pliers, lightly pinch the mini-clamp cover and, after ensuring that the cable is securely inserted, firmly squeeze on the cover.

### Note

Squeeze on the mini-clamp cover until it is correctly locked.

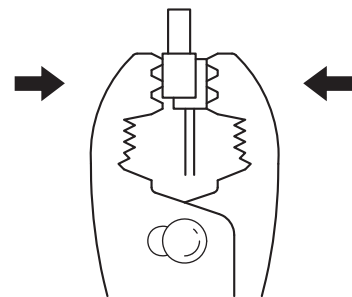

**Step 3.** Insert the wired connector (plug) into the Telephone interface unit's connector (socket) until it locks into place.

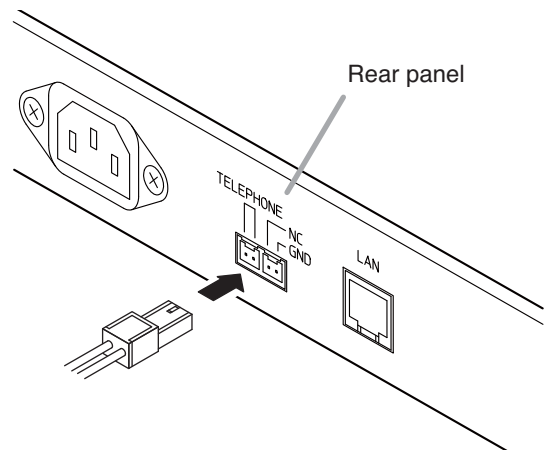

## 7. ACCESSORIES

AC power cord (2 m) .....	1	Plastic foot .....	4
CD* (for PC setting, maintenance use) .....	1	Machine screw M3 x 8 .....	4
Mini-clamp connector (2P) .....	2		

\* Contains the N-8000 setting software program and the N-8000 series instruction manual. The Setup Launcher is automatically started when the supplied CD-ROM is inserted into the PC's drive.

### Note

If your PC's CD drive is not compatible with the AutoRun function, the setup guide is not automatically started even when the CD is inserted. Use either "Explorer" or "My Computer" to execute the following files, or use [Start → Run] in the Task Bar and enter the following command.

<Drive where CD is placed> \index.html

For example, when placing the CD in the "d" drive, → d:\index.html

## 8. OPTIONAL PRODUCTS

Rack mounting bracket: MB-15B-BK (for rack mounting one N-8000AL unit)  
MB-15B-J (for rack mounting two N-8000AL units)

Wall mounting bracket: YC-850

### Version update information

- Download our TOA Products Data, web site (<http://www.toa-products.com/international/>) to get the up-to-date version for N-8000 software, firmware, and Instruction manuals.
- The software version number can be confirmed using the Help menu.
- The current firmware version can be confirmed on the system management screen displayed when the browser establishes the connection to the Exchange.
- The instruction manual version number can be confirmed by checking the preparation date (month and year) shown at the lower right corner of the last page.  
Example: Prepared in November 2004: 200411

### Traceability Information for Europe (EMC directive 2004/108/EC)

Manufacturer:  
TOA Corporation  
7-2-1, Minatojima Nakamachi, Chuo-ku, Kobe, Hyogo,  
Japan

Authorized representative:  
TOA Electronics Europe GmbH  
Suederstrasse 282, 20537 Hamburg,  
Germany



TOA Corporation

URL: <http://www.toa.jp/>

133-21-943-6A