

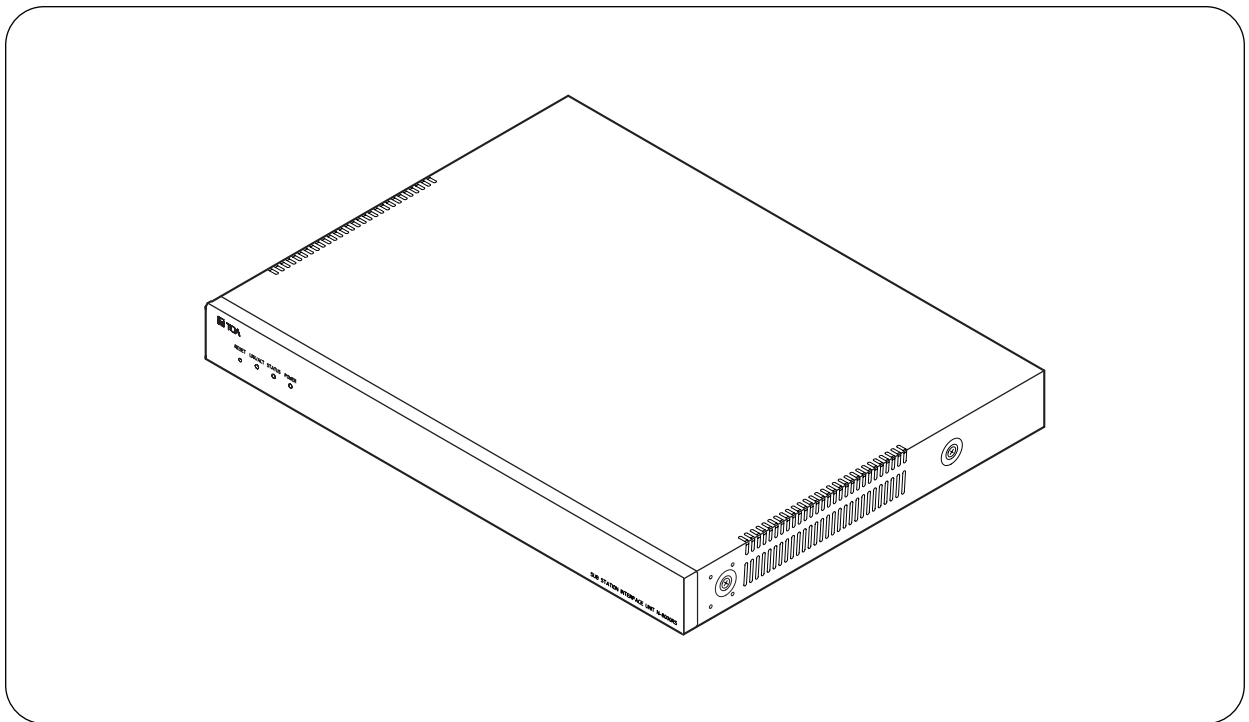

INSTALLATION MANUAL

IP INTERCOM SUBSTATION INTERFACE UNIT N-8000RS



Thank you for purchasing TOA's IP Intercom Substation Interface Unit.
Please carefully follow the instructions in this manual to ensure long, trouble-free use of your equipment.

TOA Corporation

TABLE OF CONTENTS

1. SAFETY PRECAUTIONS	3
2. GENERAL DESCRIPTION	4
3. FEATURES	4
4. NOMENCLATURE AND FUNCTIONS	
Front	5
Rear	5
5. INSTALLATION	
5.1. Equipment Rack Mounting	
5.1.1. Setting space	6
5.1.2. Caution when installing the unit	6
5.1.3. Mounting on the rack	7
5.2. Desk-Top Installation	7
5.3. Wall Mounting	8
6. WIRING	
6.1. Connection Diagram	9
6.2. Type of Cable	10
6.3. Relations Between Core Diameter of Cable and Maximum Cable Length	10
6.4. Removable Terminal Plug Connection	10
6.5. E-7000TB Terminal Board Wiring	11
7. ACCESSORIES	12
8. OPTIONAL PRODUCT	12

1. SAFETY PRECAUTIONS

- Before installation or use, be sure to carefully read all the instructions in this section for correct and safe operation.
- Be sure to follow all the precautionary instructions in this section, which contain important warnings and/or cautions regarding safety.
- After reading, keep this manual handy for future reference.

Safety Symbol and Message Conventions

Safety symbols and messages described below are used in this manual to prevent bodily injury and property damage which could result from mishandling. Before operating your product, read this manual first and understand the safety symbols and messages so you are thoroughly aware of the potential safety hazards.



Indicates a potentially hazardous situation which, if mishandled, could result in death or serious personal injury.



Indicates a potentially hazardous situation which, if mishandled, could result in moderate or minor personal injury, and/or property damage.



When Installing the Unit

- Do not expose the unit to rain or an environment where it may be splashed by water or other liquids, as doing so may result in fire or electric shock.
- Use the unit only with the voltage specified on the unit. Using a voltage higher than that which is specified may result in fire or electric shock.
- Do not cut, kink, otherwise damage nor modify the power supply cord. In addition, avoid using the power cord in close proximity to heaters, and never place heavy objects -- including the unit itself -- on the power cord, as doing so may result in fire or electric shock.
- Avoid installing or mounting the unit in unstable locations, such as on a rickety table or a slanted surface. Doing so may result in the unit falling down and causing personal injury and/or property damage.
- Install the unit only in a location that can structurally support the weight of the unit and the mounting bracket. Doing otherwise may result in the unit falling down and causing personal injury and/or property damage.

When the Unit is in Use

- Should the following irregularity be found during use, immediately disconnect the power supply plug from the AC outlet and contact your nearest TOA dealer. Make no further attempt to operate the unit in this condition as this may cause fire or electric shock.

- If you detect smoke or a strange smell coming from the unit
- If water or any metallic object gets into the unit
- If the power supply cord is damaged (exposure of the core, disconnection, etc.)
- If it is malfunctioning (no tone sounds.)
- To prevent a fire or electric shock, never open nor remove the unit case as there are high voltage components inside the unit. Refer all servicing to qualified service personnel.
- Do not insert nor drop metallic objects or flammable materials in the ventilation slots of the unit's cover, as this may result in fire or electric shock.
- Do not touch a plug during thunder and lightning, as this may result in electric shock.



When Installing the Unit

- Never plug in nor remove the power supply plug with wet hands, as doing so may cause electric shock.
- When unplugging the power supply cord, be sure to grasp the power supply plug; never pull on the cord itself. Operating the unit with a damaged power supply cord may cause a fire or electric shock.
- Do not block the ventilation slots in the unit's cover. Doing so may cause heat to build up inside the unit and result in fire. Also, periodically clean the ventilation slots of dust.

- Be sure to follow the instructions below when rack-mounting the unit. Failure to do so may cause a fire or personal injury.
 - Install the equipment rack on a stable, hard floor. Fix it with anchor bolts or take other arrangements to prevent it from falling down.
 - When connecting the unit's power cord to an AC outlet, use the AC outlet with current capacity allowable to the unit.
 - The supplied rack-mounting screws can be used for the TOA equipment rack only. Do not use them for other racks.

When the Unit is in Use

- Do not place heavy objects on the unit as this may cause it to fall or break which may result in personal injury and/or property damage. In addition, the object itself may fall off and cause injury and/or damage.
- Do not stand or sit on, nor hang down from the unit as this may cause it to fall down or drop, resulting in personal injury and/or property damage.

2. GENERAL DESCRIPTION

TOA's N-8000RS is Substation interface unit used for the N-8000 Series Packet Intercom System (IP network compatible intercom) employing packet audio technology*.

Up to 16 substations can be connected using 2-core shielded cables.

The maximum number of LAN-connectable N-8000 system components such as exchanges, IP stations, and various kinds of interface units is 192 in total.

Connecting the unit to the LAN permits the substation to receive paging calls and make calls to both the master station connected to the IP intercom exchange and the IP master station.

* Technology related to audio transmission over a network

Warning

This is a class A product. In a domestic environment this product may cause radio interference in which case the user may be required to take adequate measures.

3. FEATURES

- Exchanges, IP stations and various kinds of interface units can be connected over a data communications network.
- Can be connected to an existing local area network (LAN) or wide-area network (WAN).
- The dedicated software program enables centralized control with a personal computer.
- System maintenance (verifying operation log and Line supervision) can also be performed with a personal computer and Internet browser.
- The unit's speech links are 2 external links.

4. NOMENCLATURE AND FUNCTIONS

[Front]



1. Reset key [RESET]

Pressing this key reactivates the unit.

2. LNK/ACT indicator [LNK/ACT] (Green)

Lights when connected to a network, and flashes while transmitting or receiving data.

3. Status indicator [STATUS] (Red)

Continuously lights while data is written to an internal storage medium (FlashMemory), and flashes to indicate such unit malfunctions as internal cooling fan failure.

4. Power indicator [POWER] (Green)

Lights when power is supplied to the unit.

5. MAC address

This is the MAC address* for the unit. Since the relationship of each unit location to its MAC address is established when setting the network attributes, keep track of this relationship for later use.

* The inherent address assigned to each network component, expressed in 12-digit hexadecimal notation.

[Rear]

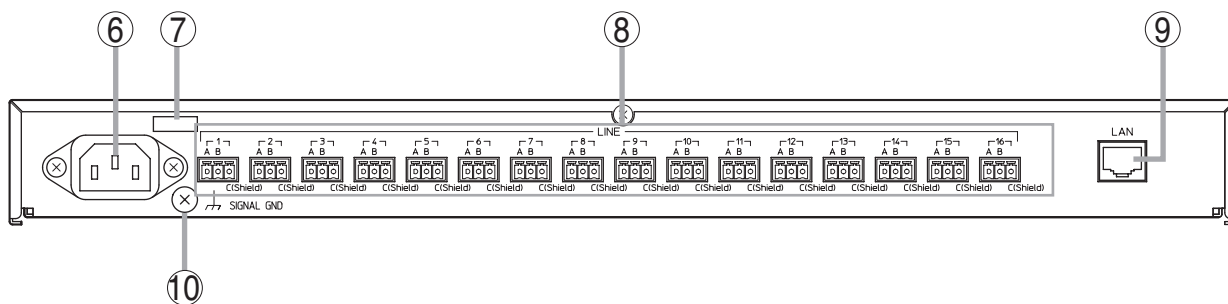

6. AC inlet

Connect the supplied power cord.

Note

If there is a danger of lightning strikes, insert an appropriate surge arrester into the power line.

7. Cord clamp

Pass the power cord through this clamp to ensure that the plug does not pull out when the unit is mounted to a wall. (Refer to p. 8.)

8. Substation connection terminals [LINE 1 – 16]

Use 2-core shielded cable to connect the substation to these terminals.

Use the supplied removable terminal plug for connection.

Refer to p.10, "Removable terminal plug connection."

9. Network connection terminal [LAN]

Connects a 10BASE-T- or 100BASE-TX-compatible network. (Ethernet RJ-45 jack)

10. Functional earth terminal [SIGNAL GND]

Ground this terminal.

Note: This terminal is not for protective earth.

5. INSTALLATION

The N-8000RS can be installed in any of three ways: (1) equipment rack mounting, (2) wall mounting, and (3) desk-top installation.

5.1. Equipment Rack Mounting

- A) Elevated Operating Ambient - If installed in a closed or multi-unit rack assembly, the operating ambient temperature of the rack environment may be greater than room ambient. Therefore, consideration should be given to installing the equipment in an environment compatible with the maximum ambient temperature (T_{ma}) specified by the manufacturer.
- B) Reduced Air Flow - Installation of the equipment in a rack should be such that the amount of air flow required for safe operation of the equipment is not compromised.
- C) Mechanical Loading - Mounting of the equipment in the rack should be such that a hazardous condition is not achieved due to uneven mechanical loading.
- D) Circuit Overloading - Consideration should be given to the connection of the equipment to the supply circuit and the effect that overloading of the circuits might have on overcurrent protection and supply wiring. Appropriate consideration of equipment nameplate ratings should be used when addressing this concern.
- E) Reliable Earthing - Reliable earthing of rack-mounted equipment should be maintained. Particular attention should be given to supply connections other than direct connections to the branch circuit (e.g. use of power strips)."

The N-8000RS can be mounted on the CR-273, CR-413, or standard EIA 19" Equipment rack. For the CR-273 and CR-413 Equipment rack assembly or BU-412 Blower unit installation, read the installation manual supplied with the rack.

Note

When installing the Blower unit and N-8000RS, lay the equipment rack down face-up to do installation work safely. Since the Blower unit is installed from the inside of the rack, be sure to install it first, before mounting the other components.

5.1.1. Setting space

For maintenance works, allow much space between the wall and Equipment rack.

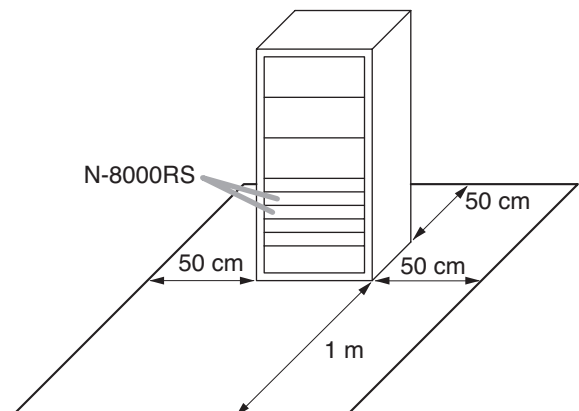

5.1.2. Caution when installing the unit

⚠ CAUTION

Do not block the ventilation slots in the unit's cover. Doing so may cause heat to build up inside the unit and result in fire.

Do not stack up 3 Substation interface units or more.

If 2 or more units are mounted in the Equipment rack, be sure to mount the perforated panel of 1-unit size (PF-013B) or more above and below every 2 units.

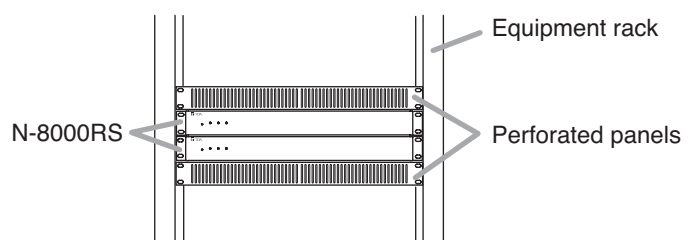

5.1.3. Mounting on the rack

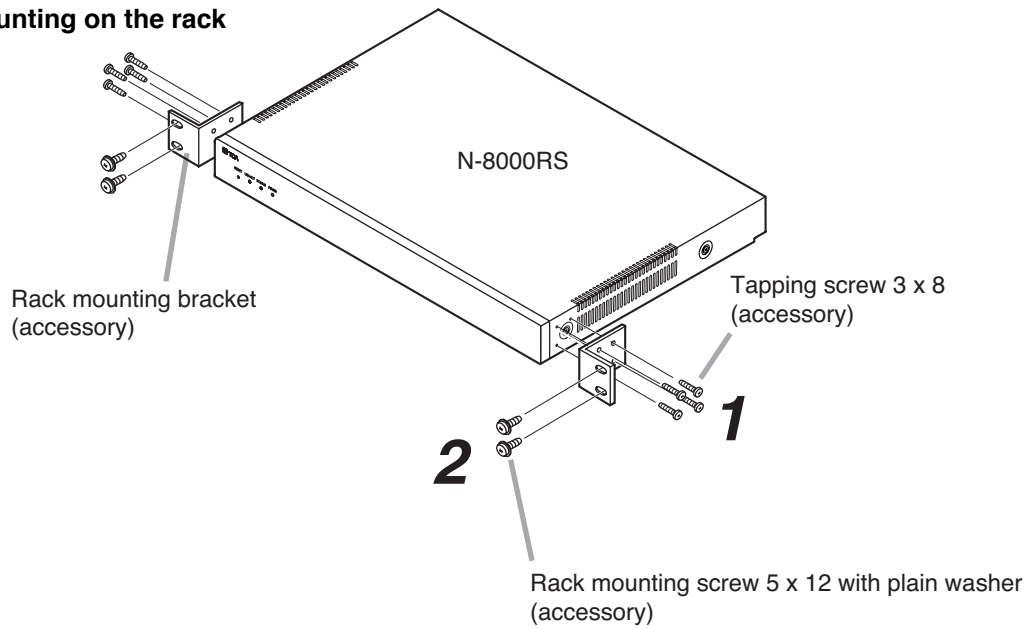

Step 1. Install the rack-mounting bracket to the N-8000RS.

Step 2. Mount the N-8000RS on the Equipment rack.

5.2. Desk-Top Installation

When installing the N-8000RS on a desk, secure the supplied plastic feet to the bottom surface of the N-8000RS using the supplied machine screws.

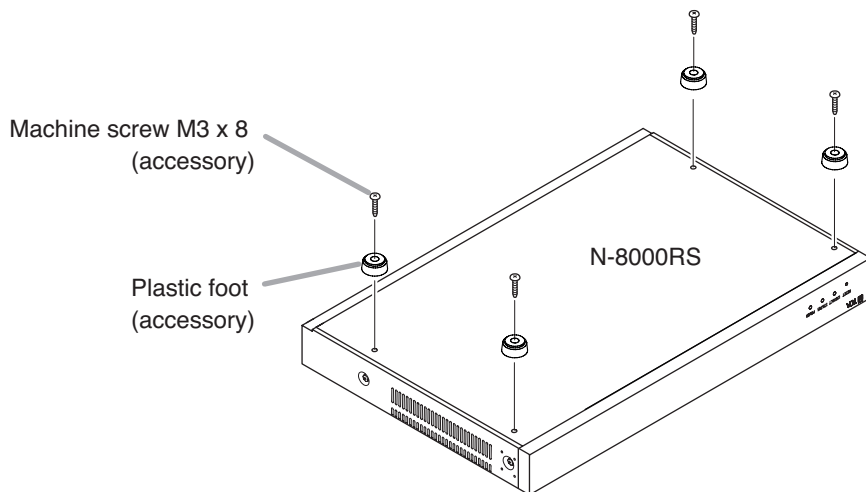

5.3. Wall Mounting

Step 1. Install the optional YC-850 Wall-mounting bracket to the N-8000RS.

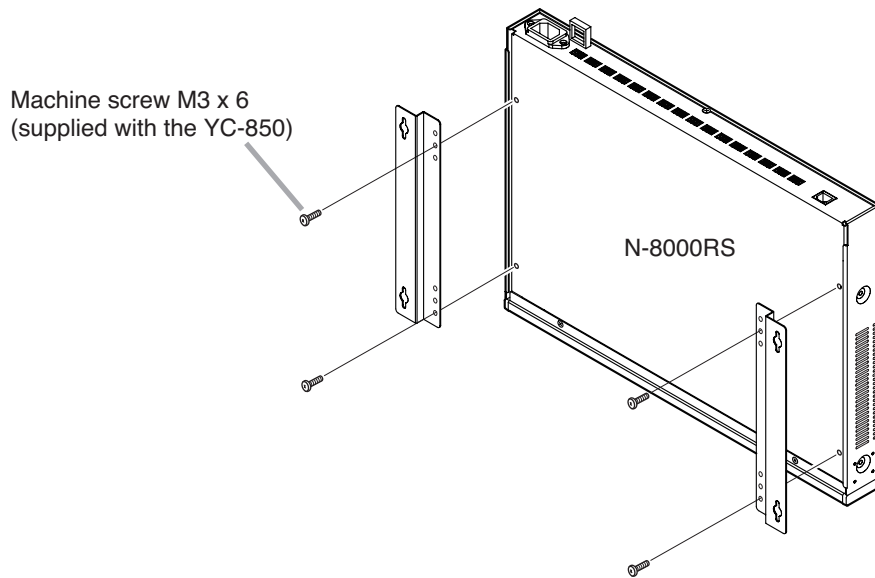

Step 2. Mount the N-8000RS on the wall.

Notes

- Use appropriate screws for the construction of wall.
- Wood screws 3.5 x 20 are supplied with the YC-850.
- The socket-outlet shall be installed near the equipment and the plug (disconnecting device) shall be easily accessible.

Protect against disconnection (Power supply plug)

Unlock cable clip and run the power supply cord through cable clip.

Note

Keep overall cable length between a power supply plug and cable clip as short as possible.

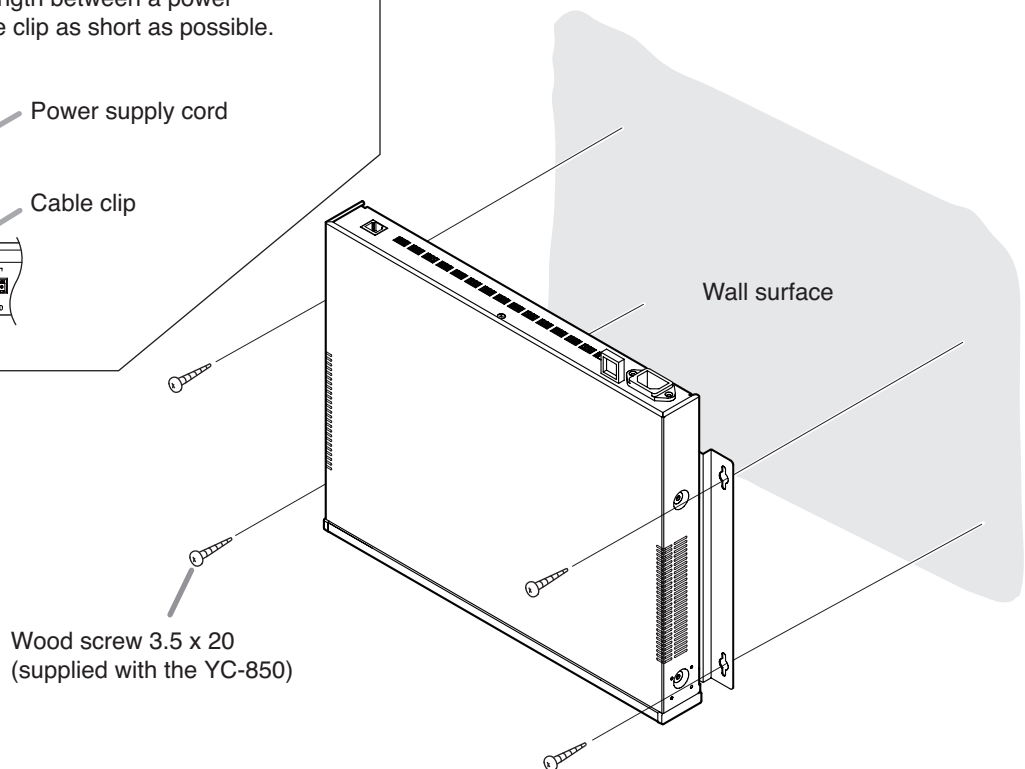
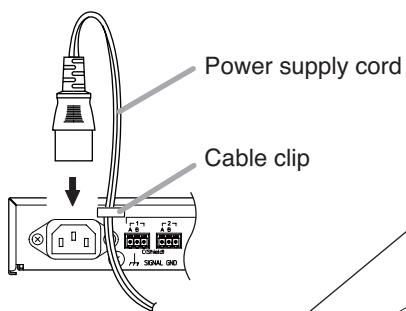

6. WIRING

6.1. Connection Diagram

N-8000RS Substation interface unit

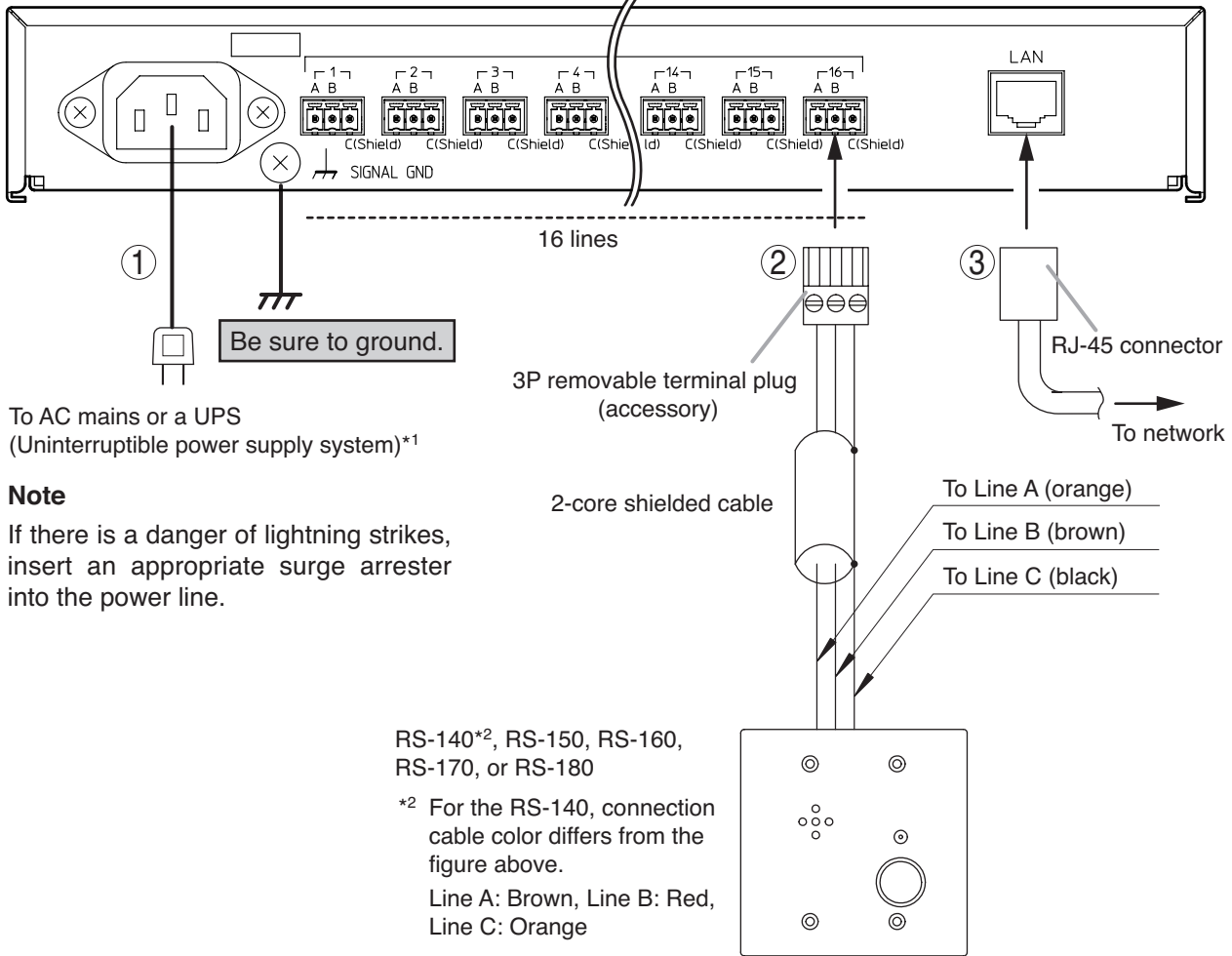

Note

If there is a danger of lightning strikes, insert an appropriate surge arrester into the power line.

Tips

- This figure represents the RS-180.
- For more information on the RS-140, RS-150, RS-160, RS-170, and RS-180, please refer to their respective installation manuals.

[General description of connection]

For cables, refer to p. 10.

1. Power supply connection

Connect the supplied power supply cord to AC Mains or a UPS (Uninterruptible power supply).

About power supply cord handling

The supplied power supply cord is designed for exclusive use with the N-8000RS. Never use it with other equipment.

2. Substation Connections

(Refer to p. 10, "Removable terminal plug connection.")

3. Network connection

Can be connected to a network of 10BASE-T/100BASE-TX in auto-sensing. Use a straight through cable of UTP category 5 or more for this connection.

*1 Select an appropriate UPS taking into consideration the total power consumption of all system components and the required backup time. On-line uninterruptible power supply (UPS) is recommended.

Reference

Substation interface unit N-8000RS: 40 W (rated) for CE version, 35 W (rated) for CU version
 8-Port 10M/100M Switching Hub: Approx. 10 W (Differs depending on products.)

6.2. Type of Cable

The types of cables are to be determined according to the following conditions.

- UTP Category 5 straight through cable with RJ45 connectors is to be used for connecting to IP network.
- The number of cables pairs laid should be determined considering the possibility of future expansion of the system.
- Outdoor wires should be used where wiring passes through inaccessible areas such as attics or under floors where the maintenance is not performed. Indoor wires may also be used, however, in case where there is no risk of deterioration due to exposure to heat, etc.
- Make sure that the 2-core shielded cable is used for wiring from the substation interface unit to the substation (RS-150, RS-160, RS-170, and RS-180).

Note

Specifications related to connections are as follows.

Removable terminal plug (N-8000RS line terminal)

Conductor diameter: \varnothing 0.5 – 2 mm (AWG12 – 24), Solid wire/Stranded wire

Clip terminal (E-7000TB)

Conductor diameter: \varnothing 0.4 – 0.8 mm (AWG20 – 26), Solid wire

Outside diameter: \varnothing 0.5 mm or below

6.3. Relations Between Core Diameter of Cable and Maximum Cable Length

For the maximum cable (2-core shielded) length between the substation interface unit and the substation (RS-150, RS-160, RS-170, and RS-180), refer to the following table.

Conductor diameter (mm)	Maximum cable length (km)
\varnothing 0.5	0.5
\varnothing 0.65	0.8
\varnothing 0.9	1.3

6.4. Removable Terminal Plug Connection

Step 1. Strip a cable jacket of approx. 7 mm to expose inner cable.

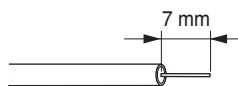

For cables, refer to above "Type of Cable."

Note

Do not solder on exposed inner cables when using a stranded wire.

Step 2. Loosen the terminal screws and insert the cables.

Step 3. Tighten the terminal screws securely.

Notes

- Tug lightly on the cable to be sure that it does not pull free. If the cable pulls free, loosen the terminal screw again and reconnect from **Step 2**.
- Use the screwdriver appropriate to the screws tightened into the terminal plug.

Step 4. Insert the wired terminal plug into the terminal block of the N-8000RS.

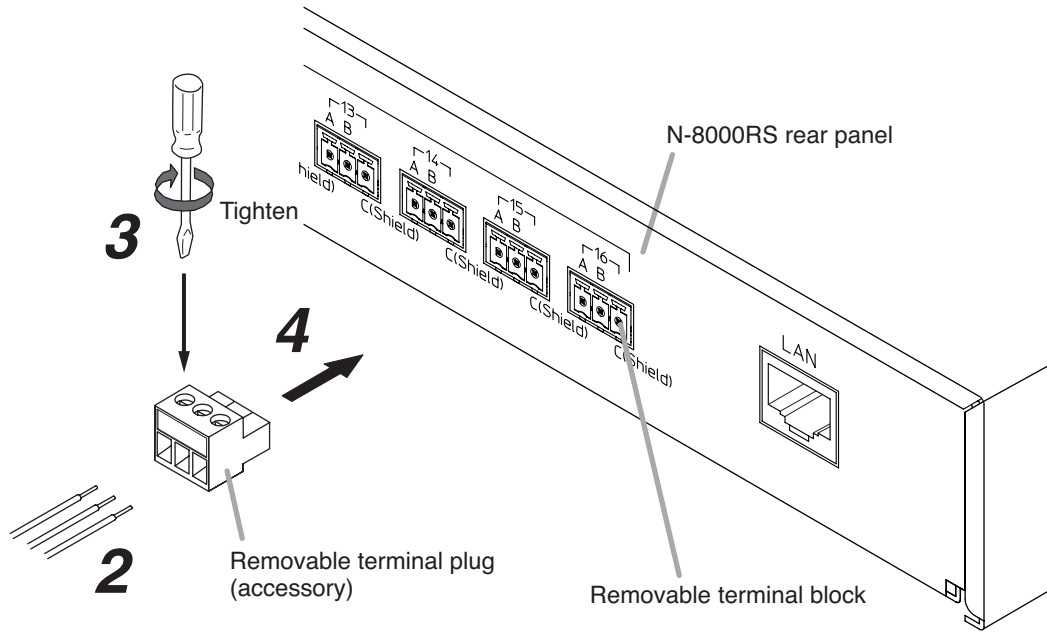

6.5. E-7000TB Terminal Board Wiring

For cable connection to the E-7000TB Terminal Board, use the optional YC-105 Clipping tool. Hook the end of the cable onto the terminal and, with the cable end in hand, press the YC-105 down onto the terminal from above. Pressing down the YC-105 tool cuts off the excess cable end, securing the connection.

For cables, refer to p. 10, "Type of Cable."

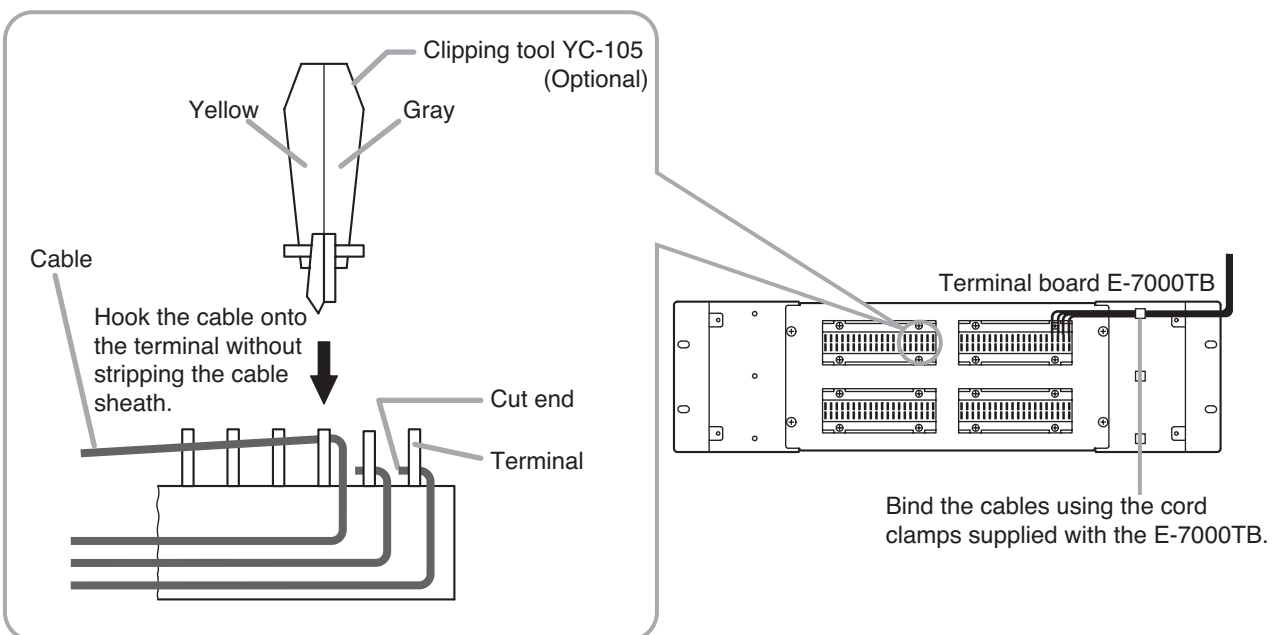

7. ACCESSORIES

AC power cord (2 m)	1	Machine screw M3 x 8	4
CD * (for PC setting, maintenance use)	1	Rack mounting bracket	2
Removable terminal plug (3 pins)	16	Tapping screw 3 x 8	8
Plastic foot	4	Rack mounting screw 5 x 12 with plain washer	4

* Contains the N-8000 Setting software program and the N-8000 series instruction manual. The Setup Launcher is automatically started when the supplied CD-ROM is inserted into the PC's drive.

Note

If your PC's CD drive is not compatible with the AutoRun function, the setup guide is not automatically started even when the CD is inserted. Use either "Explorer" or "My Computer" to execute the following files, or use [Start → Run] in the Task Bar and enter the following command.

<Drive where CD is placed> \index.html

For example, when placing the CD in the "d" drive, → d:\index.html

8. OPTIONAL PRODUCT

Wall mounting bracket: YC-850

Version update information

- Download our TOA Products Data, web site (<http://www.toa-products.com/international/>) to get the up-to-date version for N-8000 software, firmware, and Instruction manuals.
- The current firmware version can be confirmed on the system management screen displayed when the browser establishes the connection to the Substation interface unit.
- The software version number can be confirmed using the Help menu.
- The instruction manual version number can be confirmed by checking the preparation date (month and year) shown at the lower right corner of the last page.
Example: Prepared in September 2009: 200909

Traceability Information for Europe (EMC directive 2004/108/EC)

Manufacturer:
TOA Corporation
7-2-1, Minatojima Nakamachi, Chuo-ku, Kobe, Hyogo,
Japan

Authorized representative:
TOA Electronics Europe GmbH
Suederstrasse 282, 20537 Hamburg,
Germany